



© 2024 LINCOLN LABORATORY, MASSACHUSETTS INSTITUTE OF TECHNOLOGY

Dr.-Ing. Habil Ulrich L. Rohde

**A complete practical and mathematical treatment of
Microwave LC-Based Oscillators using Bipolar, MESFETs
and CMOS Transistors**

Ulrich L. Rohde¹

Microwave Systems

Department of Technical Informatics

University of the Armed Forces, Munich, Germany

Brandenburgischen Technischen Universität Cottbus–Senftenberg

Rohde & Schwarz , Munich , Synergy Microwave , USA

Based in part on the Wiley Books

The Design of modern Microwave Oscillators for Wireless Applications ,Ulrich L.

Rohde , Ajay K. Poddar, Georg Boeck 2005

Microwave and Wireless Synthesizers: Theory and Design, 2nd Edition

[Ulrich L. Rohde](#) , [Enrico Rubiola](#) , [Jerry C. Whitaker](#) , 2021

October 8, 2024

160 GHz Oscillator – Measured Phase Noise Plot



OUTLINE

- **Introduction**
- **What is an oscillator?**
- **Introduction to Microwave Oscillators and Their Mathematical Treatment**
- **Transistor Types**
- **Transistor models and Noise Contributions**
- **Linear Approach to the Calculation of Oscillator Phase Noise**
- **Typical Microwave Oscillator (Colpitts Oscillator)**
- **Designing an Oscillator**
- **Tuning Diode Noise Contribution**
- **Designing an Oscillator based on Linear S-Parameters**
- **Large signal Operation of Oscillators (Colpitts/YIG)**
- **Classical Linear Two-Port Oscillator Design**
- **Microwave Resonators**
- **A Novel Tunable Active Spiral Inductor**
- **The Active Inductor Using a Gyrator**
- **INTRODUCTION: Active Inductor Oscillator**
- **Synthesized Inductor Circuits**
- **Phase Noise Contribution of the Various Parts of the Oscillator Using an Active Inductor**
- **The Modern Time-Domain Behavior of an Oscillator**
- **Test Case: Design Example of a 100MHz crystal oscillator**
- **Phase Noise Analysis Based on the Negative Resistance Model**
- **Oscillator Phase Noise**
- **Design Examples of Oscillators for Best Phase Noise and Good Output Power**
- **Phase Noise of the integrated CMOS oscillator**
- **Appendix: A Solution for Calculating Phase Noise in Oscillators**
 - **Oscillator Noise Models**
 - **Noise Generation in Oscillators**
- **Key References**

➤ DEFINITION OF AN OSCILLATOR

- **An Oscillator is an Electronic Circuit that converts DC power to RF power, this can range from a few Hz to Tera Hz and higher**
- **An oscillator consists of an active device acting as an amplifier, a resonator, and a feedback circuit**
- **A small amount of energy feedback is needed to sustained oscillation and the majority of available energy appears at the output terminals**
- **Resonators can be LC based circuits, transmission line based, crystal, ceramic, dielectric resonator, YIG (Yttrium Garnet) based, and others**

For RF application, the most relevant features besides size are:

- **Output power**
- **Harmonic content**
- **Phase Noise**
- **Power consumptions, to name a few**

OSCILLATOR BASICS

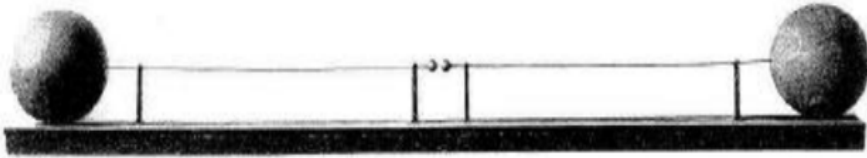

Original dipole made by Heinrich Hertz in 1887 using balls at the end to form a capacitive load (Deutsches Museum, Munich)

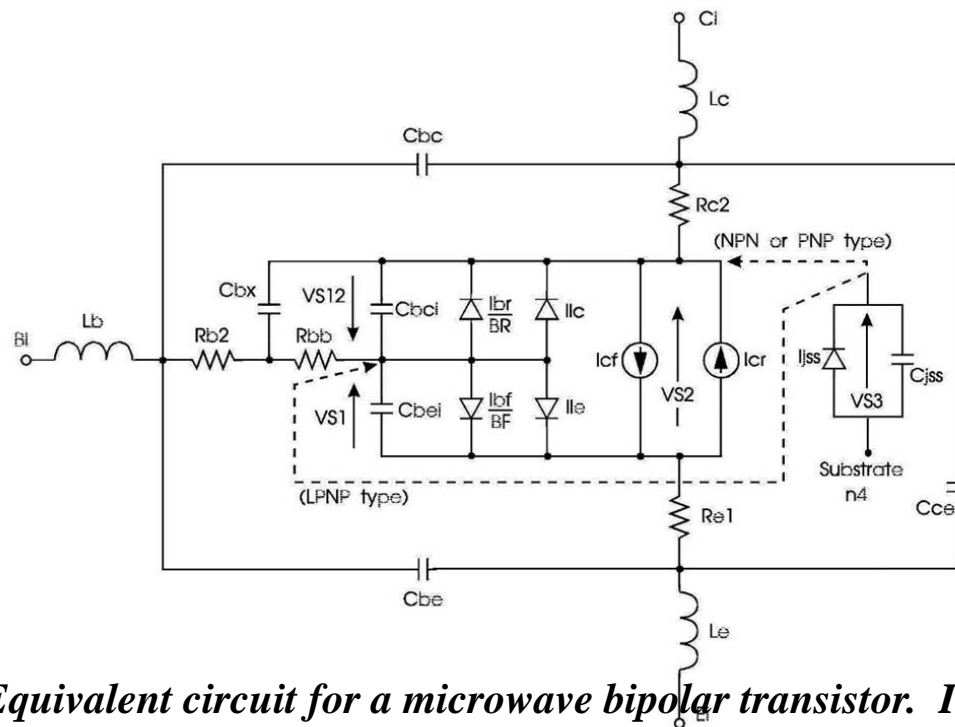

Equivalent circuit for a microwave bipolar transistor. It deviates from the SPICE implementation by having two base-spreading resistors

Oscillator type	Bipolar transistor RF circuit	FET RF circuit
Hartley		
Colpitts		
Clapp (OURIET)		

Basic Oscillator Configurations

➤ OSCILLATOR BASICS

A typical linear oscillator phase noise model (block diagram) Leeson Model

The resulting phase noise in linear terms can be calculated as

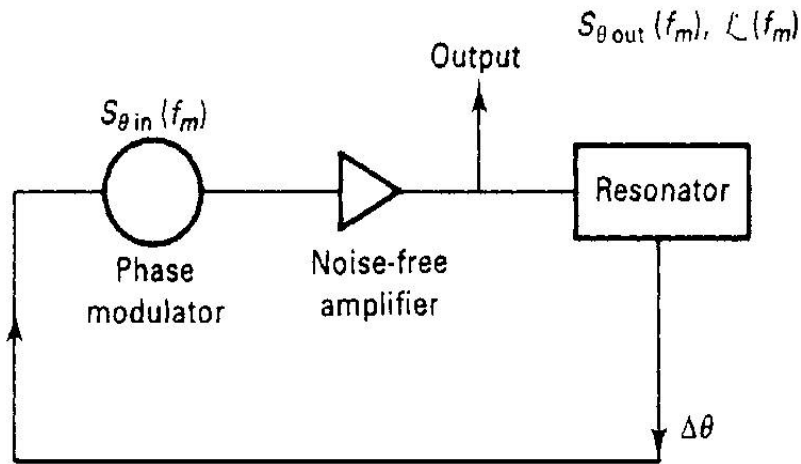

$$L(f_m) = \frac{1}{2} \left[1 + \frac{\omega_o^2}{4\omega_m^2} \left(\frac{P_{in}}{\omega_o W_e} + \frac{1}{Q_{uni}} + \frac{P_{sig}}{\omega_o W_e} \right)^2 \right] \left(1 + \frac{\omega_c}{\omega_m} \right) \frac{FkT_o}{P_{sav}}$$

Diagram illustrating the components of the Leeson equation:

- input power over reactive power
- resonator Q
- signal power over reactive power
- flicker effect
- phase perturbation

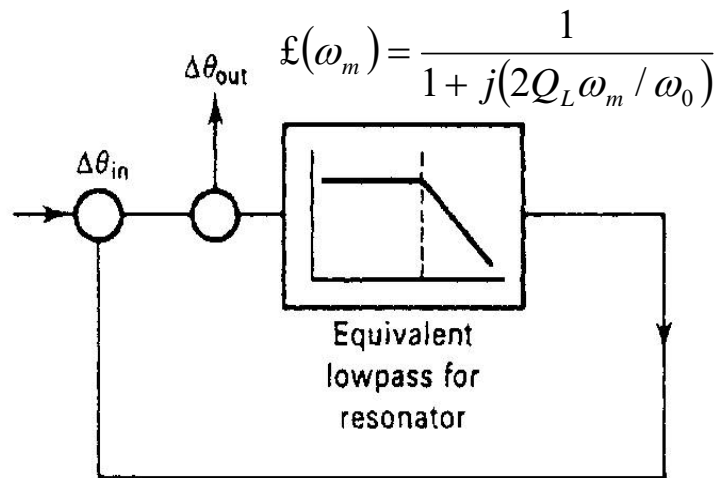

This equation is the linear Leeson equation, with the pushing effect omitted and the flicker term added by Dieter Scherer (Hewlett Packard, about 1975).

Phase noise is a dimensionless number, and expressed in dBc/Hz, measured at an offset of Δf (f_m) from the carrier relative to the RF output power. At 0 dBm output, the ideal phase noise level far off the carrier is -174dB ($T_0 = 300$ Kelvin)

Two Stage FET Based Microwave Tunable Oscillator Built On GaAs Substrate

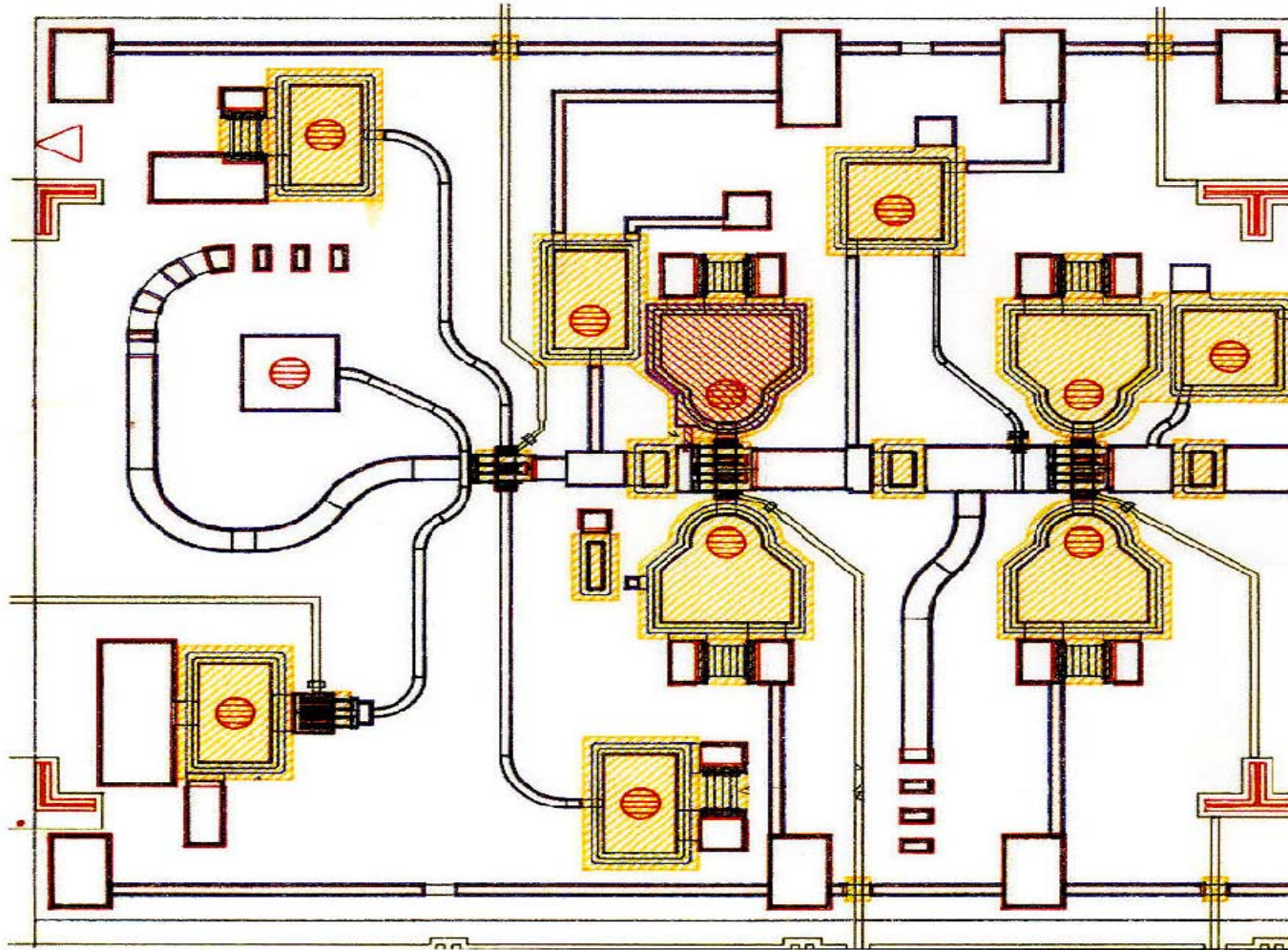

Eliot Cohen, "The MIMIC Program - A Retrospective", *Microwave Magazine*, June 2012, pp. 77-88

Serenade Program developed under the MIMIC Program

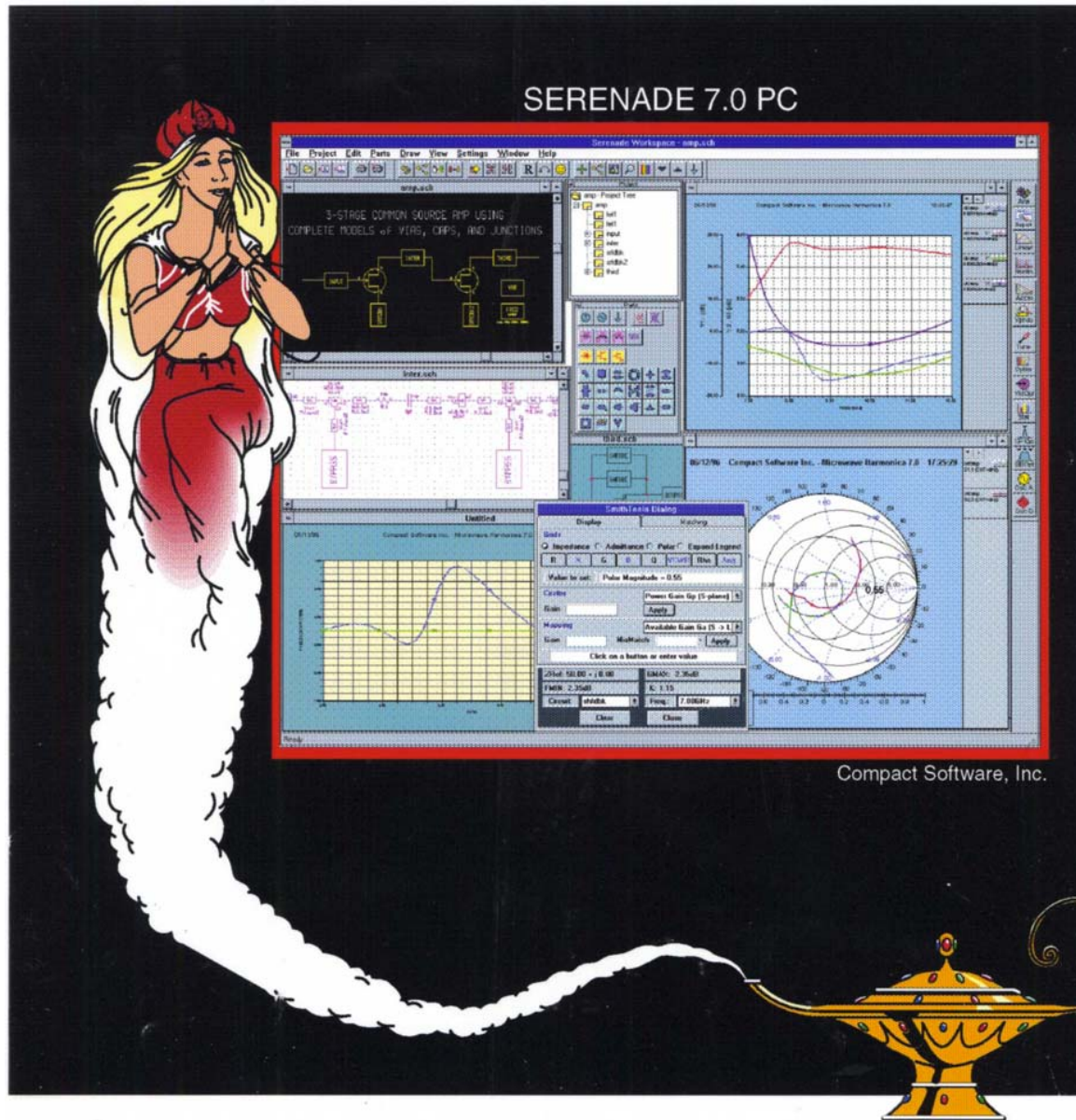

This CAD tool was developed under the MIMIC Program

A detailed mathematical analysis of the time-domain behavior of oscillators, intended as a stand-alone mathematical derivation was developed between Prof. Rizzoli and team from the University of Bologna, Rowan Gilmore and Prof. Fred Rosenbaum from the University of Washington, St. Louis, and my team at Compact Software, where we introduced the world's first harmonic balance mathematics based simulator, that could handle nonlinear noise in amplifiers, frequency doublers, mixers and finally oscillators.

The DARPA program manager was Dr. Eliot Cohen. In 2012 Eliot Cohen wrote an article on the MIMIC Program for IEEE MTT-S [Microwave Magazine](#) which is a good resource if you want to learn about this historic program. Here are the details:

Eliot Cohen, "The MIMIC Program - A Retrospective", *Microwave Magazine*, June 2012, pp. 77-88

OUTLINE

- **Introduction**
- **What is an oscillator?**
- **Introduction to Microwave Oscillators and Their Mathematical Treatment**
- **Transistor Types**
- **Transistor models and Noise Contributions**
- **Linear Approach to the Calculation of Oscillator Phase Noise**
- **Typical Microwave Oscillator (Colpitts Oscillator)**
- **Designing an Oscillator**
- **Tuning Diode Noise Contribution**
- **Designing an Oscillator based on Linear S-Parameters**
- **Large signal Operation of Oscillators (Colpitts/YIG)**
- **Classical Linear Two-Port Oscillator Design**
- **Microwave Resonators**
- **A Novel Tunable Active Spiral Inductor**
- **The Active Inductor Using a Gyrator**
- **INTRODUCTION: Active Inductor Oscillator**
- **Synthesized Inductor Circuits**
- **Phase Noise Contribution of the Various Parts of the Oscillator Using an Active Inductor**
- **The Modern Time-Domain Behavior of an Oscillator**
- **Test Case: Design Example of a 100MHz crystal oscillator**
- **Phase Noise Analysis Based on the Negative Resistance Model**
- **Oscillator Phase Noise**
- **Design Examples of Oscillators for Best Phase Noise and Good Output Power**
- **Phase Noise of the integrated CMOS oscillator**
- **Appendix: A Solution for Calculating Phase Noise in Oscillators**
 - **Oscillator Noise Models**
 - **Noise Generation in Oscillators**
- **Key References**

➤ TYPICAL MICROWAVE OSCILLATOR

- Microwave oscillators are based on the negative resistance principle to compensate for the losses.
- Maximum frequency of oscillation can be determined from linear analysis for start-up conditions, but not necessarily for sustaining oscillation (large signal condition will reduce the gain and shift the frequency).
- Linear analysis is unreliable to determine resonance frequency and other dynamic parameters, beware of parasitics.

A typical block diagram of feedback oscillator circuit

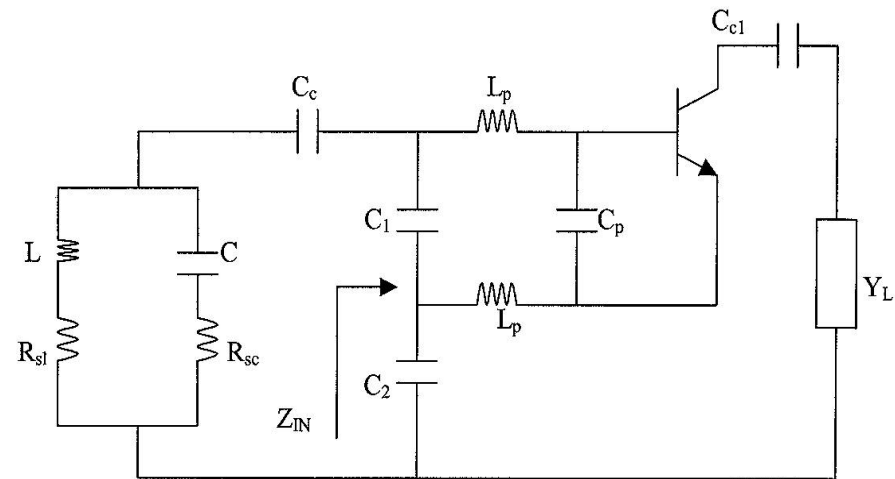
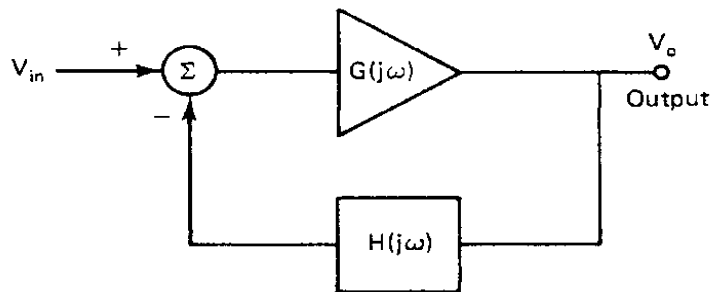

$$Z_{IN}|_{package} = - \left[\frac{Y_{21}^*}{\omega^2 (C_1 + C_p) C_2} \frac{1}{(1 + \omega^2 Y_{21}^{*2} L_p^2)} \right] - j \left[\frac{(C_1 + C_p + C_2)}{\omega (C_1 + C_p) C_2} - \frac{\omega Y_{21}^* L_p}{(1 + \omega^2 Y_{21}^{*2} L_p^2)} \frac{Y_{21}^*}{\omega (C_1 + C_p) C_2} \right]$$

Y_{21}^* = Large signal value of $g_m = Y_{21DC}$

OUTLINE

- **Introduction**
- **What is an oscillator?**
- **Introduction to Microwave Oscillators and Their Mathematical Treatment**
- **Transistor Types**
- **Transistor models and Noise Contributions**
- **Linear Approach to the Calculation of Oscillator Phase Noise**
- **Typical Microwave Oscillator (Colpitts Oscillator)**
- **Designing an Oscillator**
- **Tuning Diode Noise Contribution**
- **Designing an Oscillator based on Linear S-Parameters**
- **Large signal Operation of Oscillators (Colpitts/YIG)**
- **Classical Linear Two-Port Oscillator Design**
- **Microwave Resonators**
- **A Novel Tunable Active Spiral Inductor**
- **The Active Inductor Using a Gyrator**
- **INTRODUCTION: Active Inductor Oscillator**
- **Synthesized Inductor Circuits**
- **Phase Noise Contribution of the Various Parts of the Oscillator Using an Active Inductor**
- **The Modern Time-Domain Behavior of an Oscillator**
- **Test Case: Design Example of a 100MHz crystal oscillator**
- **Phase Noise Analysis Based on the Negative Resistance Model**
- **Oscillator Phase Noise**
- **Design Examples of Oscillators for Best Phase Noise and Good Output Power**
- **Phase Noise of the integrated CMOS oscillator**
- **Appendix: A Solution for Calculating Phase Noise in Oscillators**
 - **Oscillator Noise Models**
 - **Noise Generation in Oscillators**
- **Key References**

➤ TRANSISTOR TYPES

Bipolar Transistors

Field-Effect Transistors

GaAs FETs (MESFET)

Other....

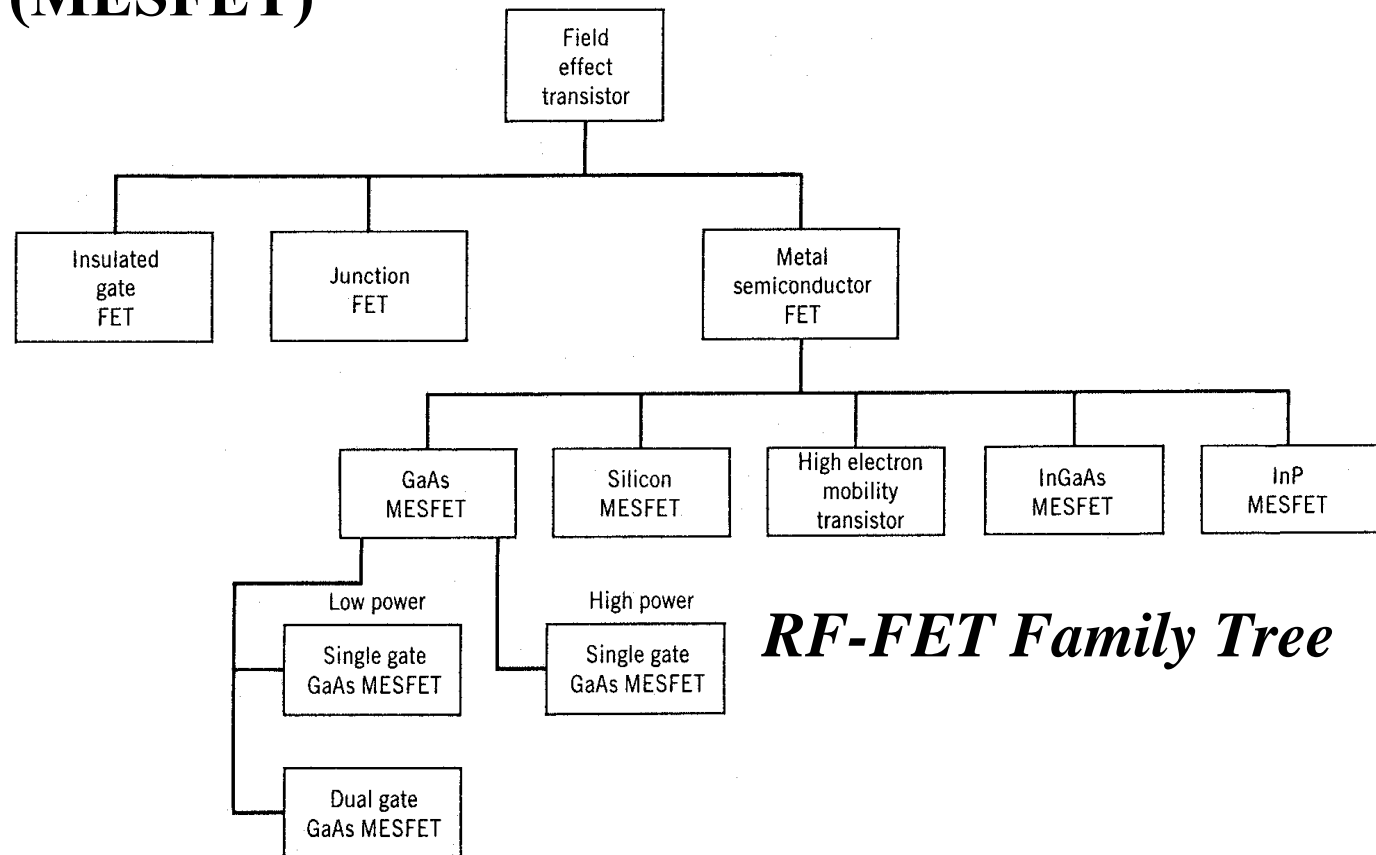

OUTLINE

- **Introduction**
- **What is an oscillator?**
- **Introduction to Microwave Oscillators and Their Mathematical Treatment**
- **Transistor Types**
- **Transistor models and Noise Contributions**
- **Linear Approach to the Calculation of Oscillator Phase Noise**
- **Typical Microwave Oscillator (Colpitts Oscillator)**
- **Designing an Oscillator**
- **Tuning Diode Noise Contribution**
- **Designing an Oscillator based on Linear S-Parameters**
- **Large signal Operation of Oscillators (Colpitts/YIG)**
- **Classical Linear Two-Port Oscillator Design**
- **Microwave Resonators**
- **A Novel Tunable Active Spiral Inductor**
- **The Active Inductor Using a Gyrator**
- **INTRODUCTION: Active Inductor Oscillator**
- **Synthesized Inductor Circuits**
- **Phase Noise Contribution of the Various Parts of the Oscillator Using an Active Inductor**
- **The Modern Time-Domain Behavior of an Oscillator**
- **Test Case: Design Example of a 100MHz crystal oscillator**
- **Phase Noise Analysis Based on the Negative Resistance Model**
- **Oscillator Phase Noise**
- **Design Examples of Oscillators for Best Phase Noise and Good Output Power**
- **Phase Noise of the integrated CMOS oscillator**
- **Appendix: A Solution for Calculating Phase Noise in Oscillators**
 - **Oscillator Noise Models**
 - **Noise Generation in Oscillators**
- **Key References**

➤ LINEAR APPROACH TO THE CALCULATION OF OSCILLATOR PHASE NOISE

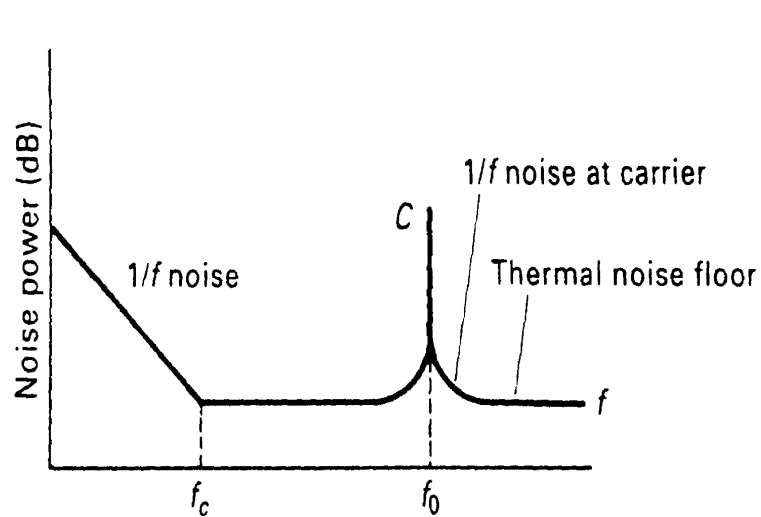

Noise power versus frequency of a transistor amplifier with an input signal applied.

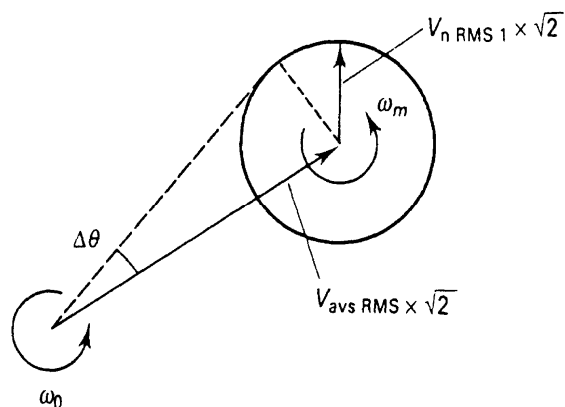
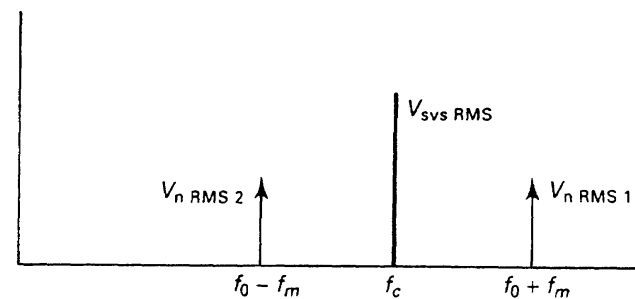
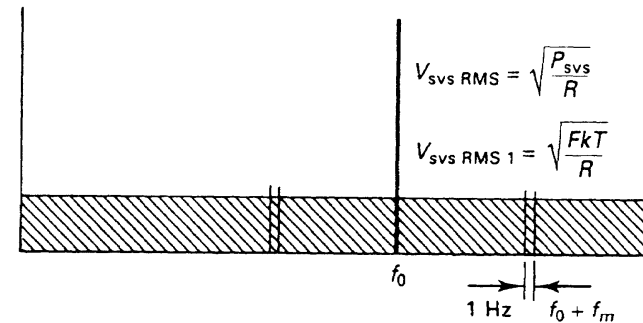
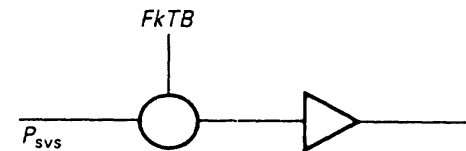

Phase noise added to carrier

➤ LINEAR APPROACH TO THE CALCULATION OF OSCILLATOR PHASE NOISE

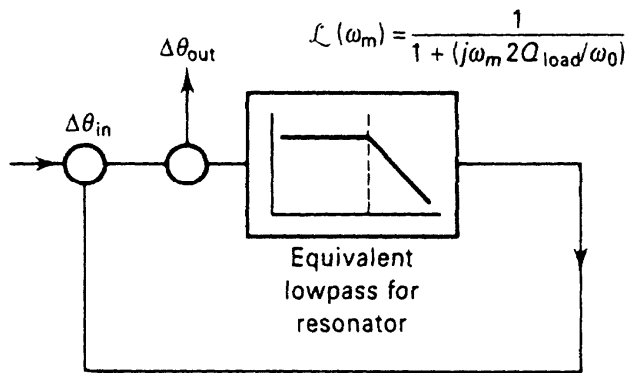
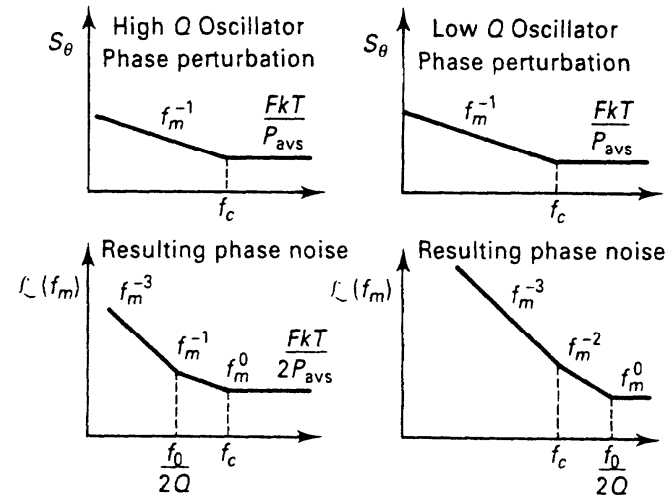
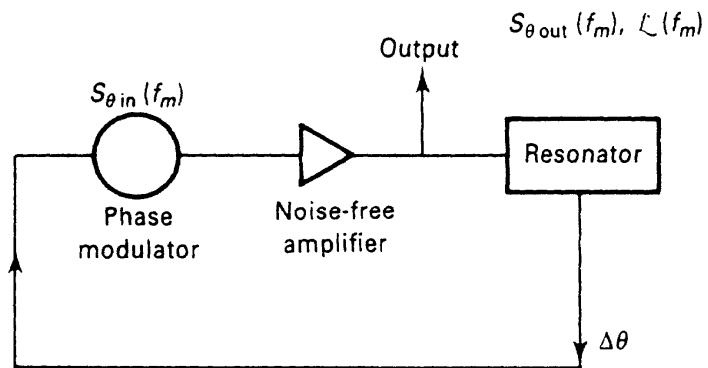

Equivalent feedback models of oscillator phase noise

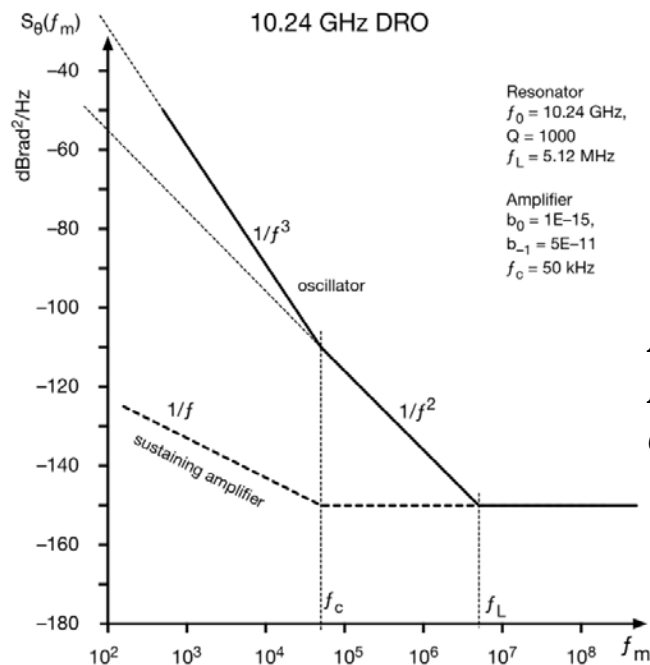

Phase Noise PSD of the 10.24 GHz DRO

OUTLINE

- **Introduction**
- **What is an oscillator?**
- **Introduction to Microwave Oscillators and Their Mathematical Treatment**
- **Transistor Types**
- **Transistor models and Noise Contributions**
- **Linear Approach to the Calculation of Oscillator Phase Noise**
- **Typical Microwave Oscillator (Colpitts Oscillator)**
- **Designing an Oscillator**
- **Tuning Diode Noise Contribution**
- **Designing an Oscillator based on Linear S-Parameters**
- **Large signal Operation of Oscillators (Colpitts/YIG)**
- **Classical Linear Two-Port Oscillator Design**
- **Microwave Resonators**
- **A Novel Tunable Active Spiral Inductor**
- **The Active Inductor Using a Gyrator**
- **INTRODUCTION: Active Inductor Oscillator**
- **Synthesized Inductor Circuits**
- **Phase Noise Contribution of the Various Parts of the Oscillator Using an Active Inductor**
- **The Modern Time-Domain Behavior of an Oscillator**
- **Test Case: Design Example of a 100MHz crystal oscillator**
- **Phase Noise Analysis Based on the Negative Resistance Model**
- **Oscillator Phase Noise**
- **Design Examples of Oscillators for Best Phase Noise and Good Output Power**
- **Phase Noise of the integrated CMOS oscillator**
- **Appendix: A Solution for Calculating Phase Noise in Oscillators**
 - **Oscillator Noise Models**
 - **Noise Generation in Oscillators**
- **Key References**

➤ TYPICAL MICROWAVE OSCILLATOR - COLPITTS OSCILLATOR

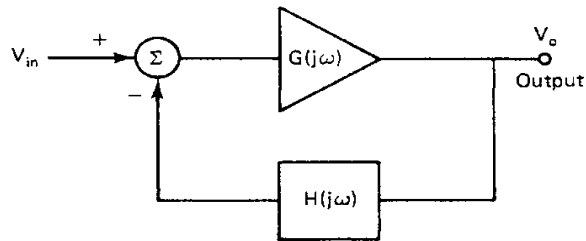

Oscillator as a feedback model and as a one port producing a loss compensation with the electronically generated negative impedance

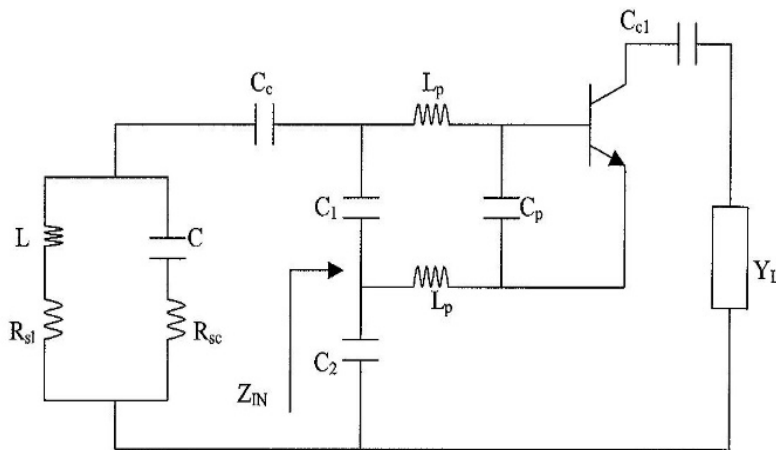

Colpitts oscillator with base-lead inductances and package capacitance. C_C is neglected

$$Z_{IN}|_{package} = - \left[\frac{Y_{21}^*}{\omega^2 (C_1 + C_p) C_2} \frac{1}{(1 + \omega^2 Y_{21}^{*2} L_p^2)} \right] - j \left[\frac{(C_1 + C_p + C_2)}{\omega (C_1 + C_p) C_2} - \frac{\omega Y_{21}^* L_p}{(1 + \omega^2 Y_{21}^{*2} L_p^2)} \frac{Y_{21}^*}{\omega (C_1 + C_p) C_2} \right]$$

$$Y_{21}^* = \text{Large signal value of } gm = Y_{21}$$

$$\mathcal{L}(f_m) = \frac{1}{2} \left[1 + \frac{\omega_o^2}{4\omega_m^2} \left(\frac{P_{in}}{\omega_o W_e} + \frac{1}{Q_{unl}} + \frac{P_{sig}}{\omega_o W_e} \right)^2 \right] \left(1 + \frac{\omega_c}{\omega_m} \right) \frac{FkT_o}{P_{sav}}$$

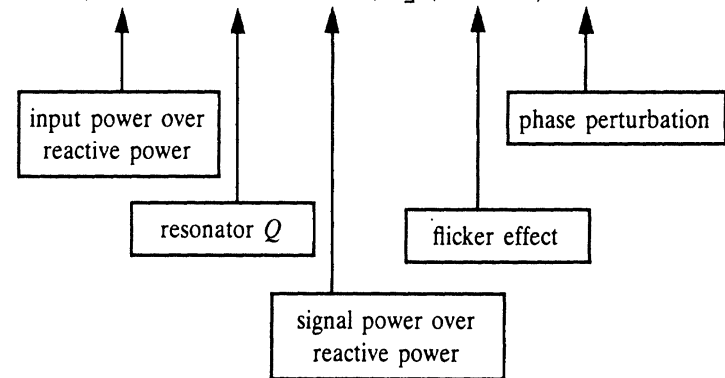

OUTLINE

- **Introduction**
- **What is an oscillator?**
- **Introduction to Microwave Oscillators and Their Mathematical Treatment**
- **Transistor Types**
- **Transistor models and Noise Contributions**
- **Linear Approach to the Calculation of Oscillator Phase Noise**
- **Typical Microwave Oscillator (Colpitts Oscillator)**
- **Designing an Oscillator**
- **Tuning Diode Noise Contribution**
- **Designing an Oscillator based on Linear S-Parameters**
- **Large signal Operation of Oscillators (Colpitts/YIG)**
- **Classical Linear Two-Port Oscillator Design**
- **Microwave Resonators**
- **A Novel Tunable Active Spiral Inductor**
- **The Active Inductor Using a Gyrator**
- **INTRODUCTION: Active Inductor Oscillator**
- **Synthesized Inductor Circuits**
- **Phase Noise Contribution of the Various Parts of the Oscillator Using an Active Inductor**
- **The Modern Time-Domain Behavior of an Oscillator**
- **Test Case: Design Example of a 100MHz crystal oscillator**
- **Phase Noise Analysis Based on the Negative Resistance Model**
- **Oscillator Phase Noise**
- **Design Examples of Oscillators for Best Phase Noise and Good Output Power**
- **Phase Noise of the integrated CMOS oscillator**
- **Appendix: A Solution for Calculating Phase Noise in Oscillators**
 - **Oscillator Noise Models**
 - **Noise Generation in Oscillators**
- **Key References**

➤ DESIGNING AN OSCILLATOR

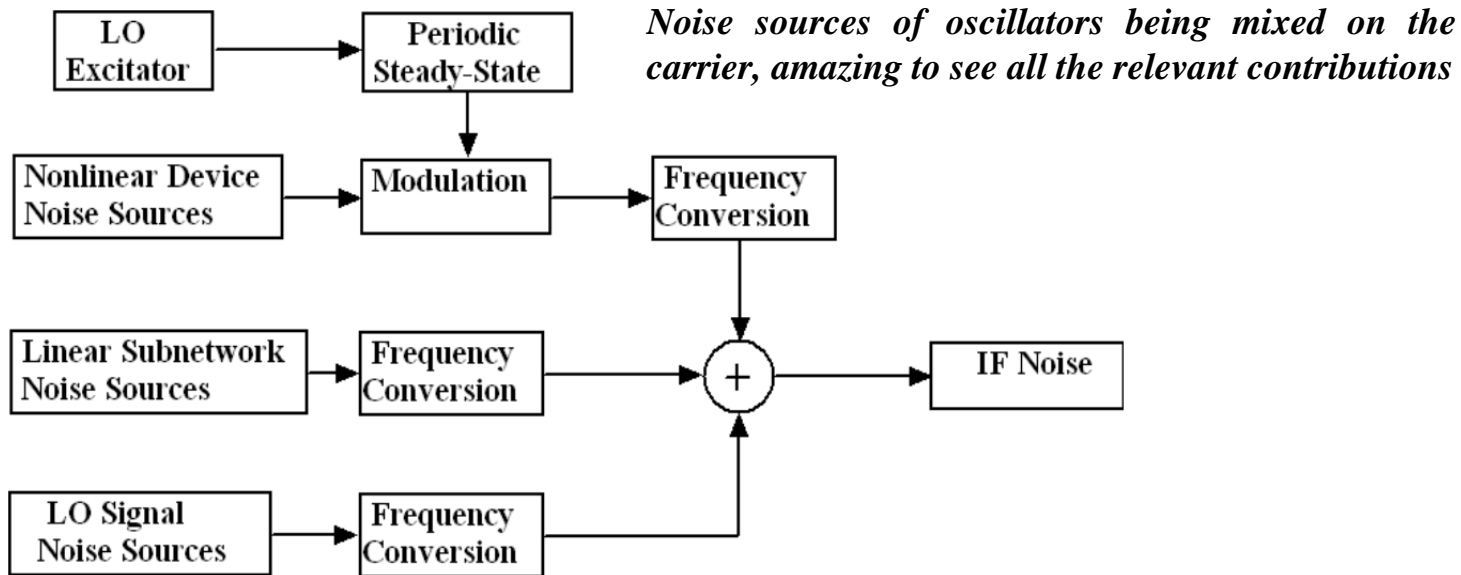

*Typical phase noise of a PLL
50 GHz PLL synthesizer*

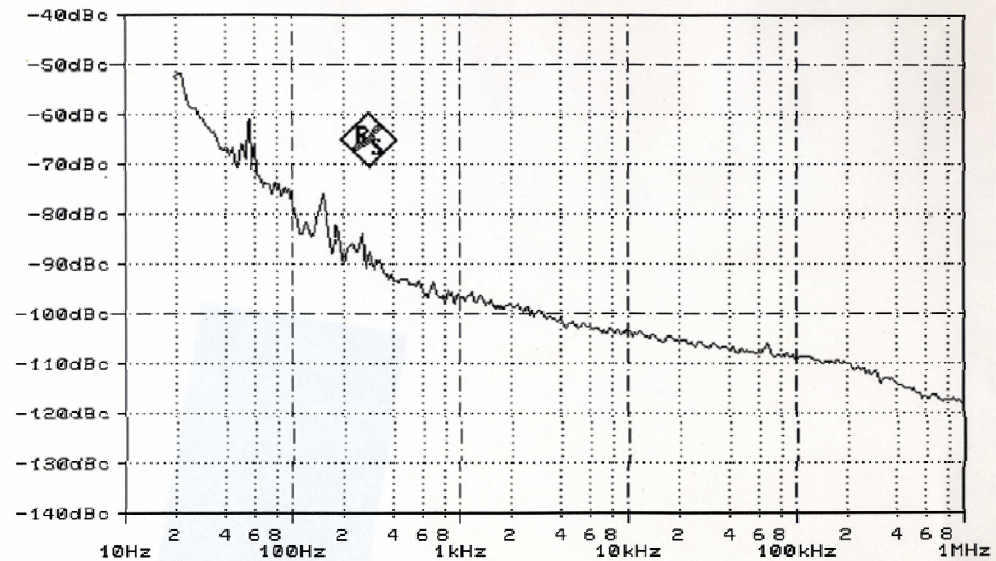

➤ DESIGNING AN OSCILLATOR

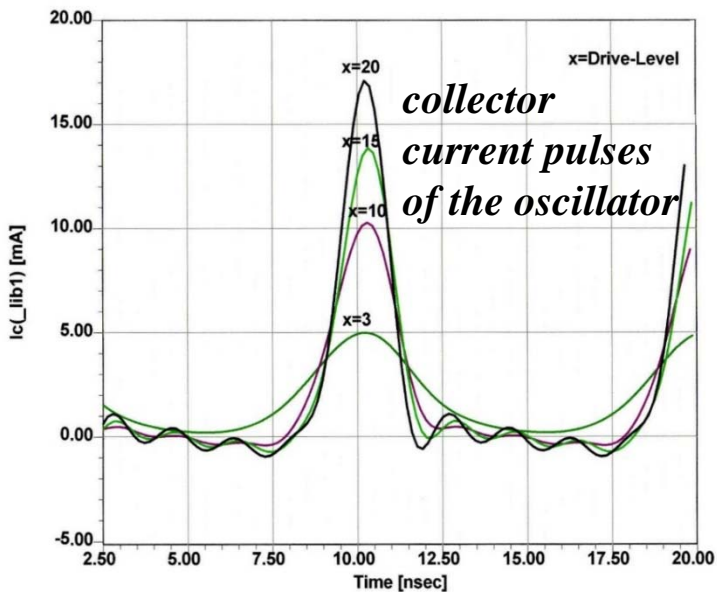
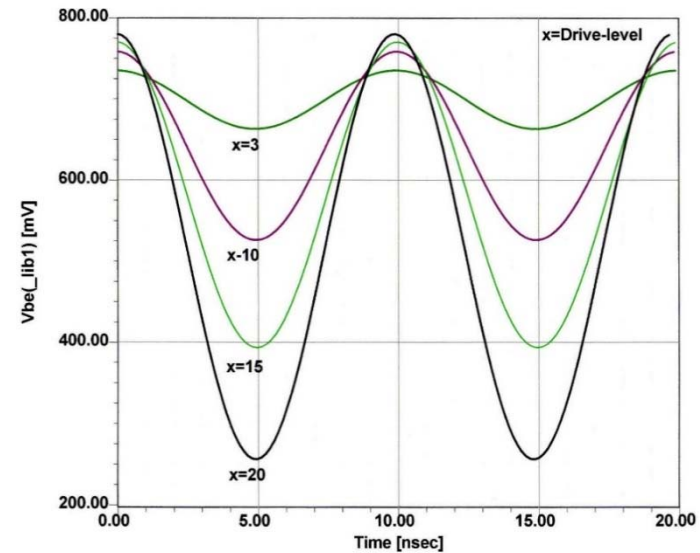
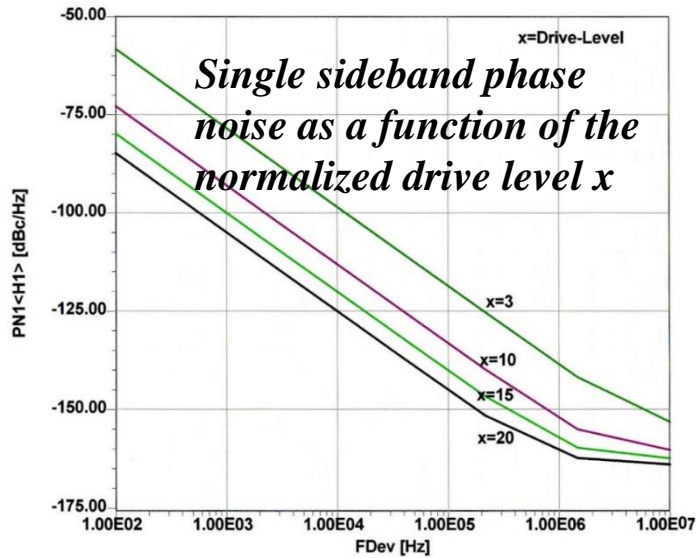

RF voltage V_{be} across the base-emitter junction as a function of the normalized drive level x

As the driven voltage $V_1(\cos(\omega t))$ increases and develops enough amplitude across the base-emitter junction, the resulting current is a periodic series of pulses whose amplitude depends on the nonlinear characteristics of the device

➤ LC OSCILLATOR PHASE NOISE

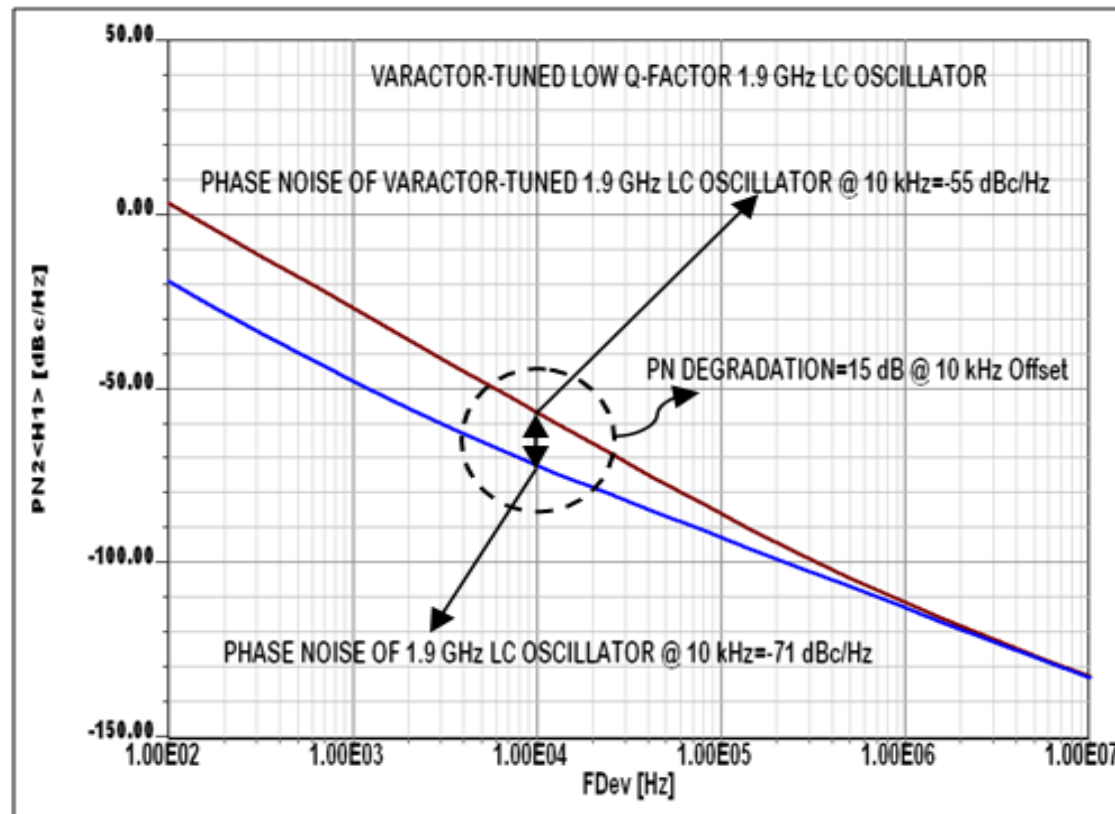

The Leeson phase noise equation is modified to accommodate the tuning diode noise contribution

$$\mathcal{L}(f_m) = 10 \log \left\{ \left[1 + \frac{f_0^2}{(2f_m Q_0)^2 m^2 (1-m)^2} \right] \left(1 + \frac{f_c}{f_m} \right) \frac{FkT}{2P_0} + \frac{2kTRK}{f_m^2} \frac{2}{0} \right\} \quad m = \frac{Q_L}{Q_0}$$

The Equation above explain the phase noise degradation (as compared to the fixed frequency LC oscillator due to the oscillator voltage gain K_0 associated with the tuning diode network as described by Rohde). The reason for noise degradation is due to the increased tuning sensitivity of the varactor diode tuning network.

➤ CONDITION FOR OSCILLATIONS

Real and imaginary values for Z_{11}

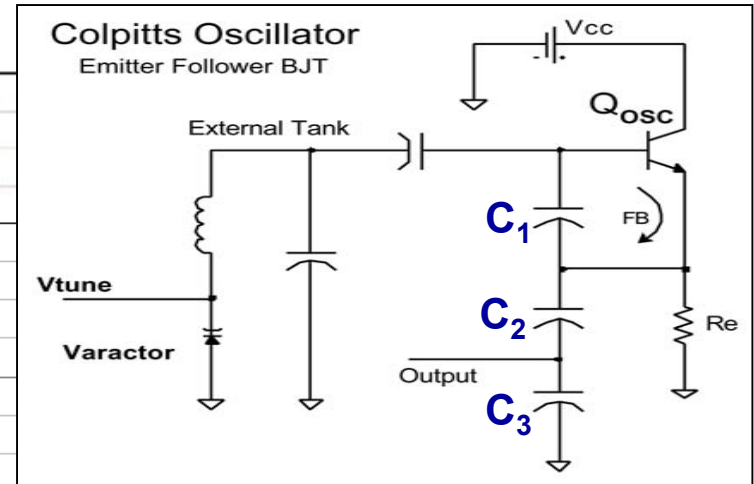
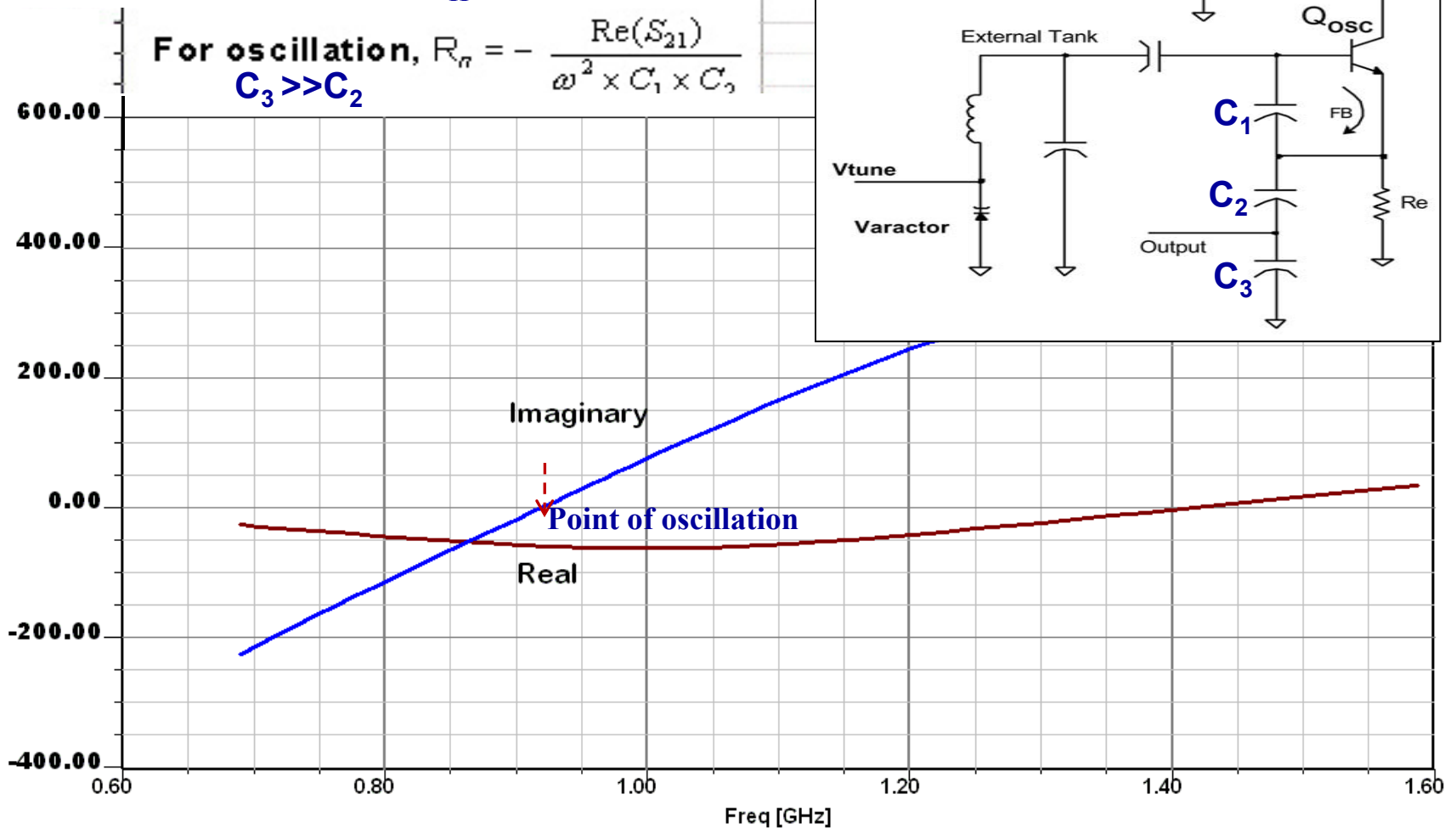

Real (Z_{11}) must be slightly more negative than the loss resistance in the circuit for oscillation to start. The resulting dc shift in the transistor will then provide the amplitude stabilization as g_m will be reduced.

OUTLINE

- **Introduction**
- **What is an oscillator?**
- **Introduction to Microwave Oscillators and Their Mathematical Treatment**
- **Transistor Types**
- **Transistor models and Noise Contributions**
- **Linear Approach to the Calculation of Oscillator Phase Noise**
- **Typical Microwave Oscillator (Colpitts Oscillator)**
- **Designing an Oscillator**
- **Tuning Diode Noise Contribution**
- **Designing an Oscillator based on Linear S-Parameters**
- **Large signal Operation of Oscillators (Colpitts/YIG)**
- **Classical Linear Two-Port Oscillator Design**
- **Microwave Resonators**
- **A Novel Tunable Active Spiral Inductor**
- **The Active Inductor Using a Gyrator**
- **INTRODUCTION: Active Inductor Oscillator**
- **Synthesized Inductor Circuits**
- **Phase Noise Contribution of the Various Parts of the Oscillator Using an Active Inductor**
- **The Modern Time-Domain Behavior of an Oscillator**
- **Test Case: Design Example of a 100MHz crystal oscillator**
- **Phase Noise Analysis Based on the Negative Resistance Model**
- **Oscillator Phase Noise**
- **Design Examples of Oscillators for Best Phase Noise and Good Output Power**
- **Phase Noise of the integrated CMOS oscillator**
- **Appendix: A Solution for Calculating Phase Noise in Oscillators**
 - **Oscillator Noise Models**
 - **Noise Generation in Oscillators**
- **Key References**

➤ DESIGNING AN OSCILLATOR BASED ON LINEAR S-PARAMETERS

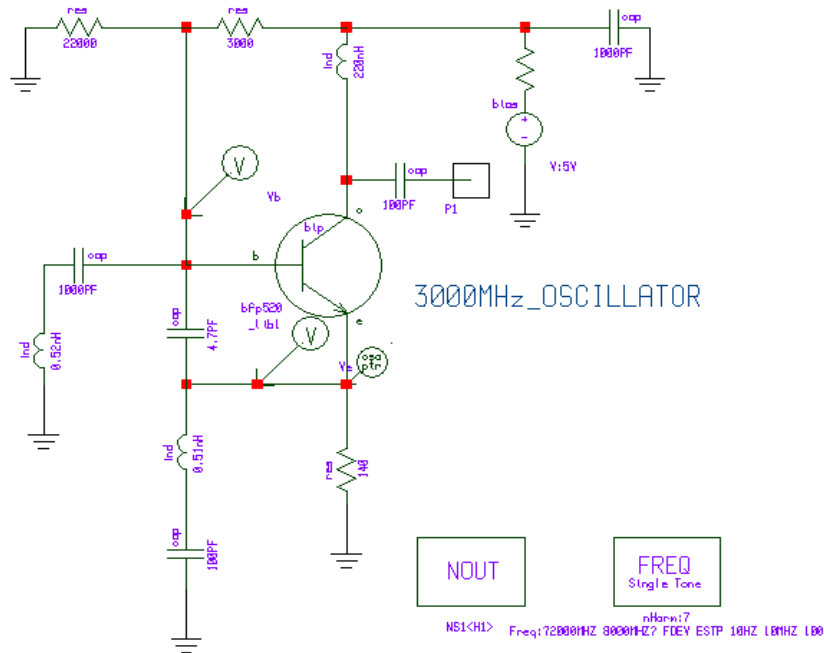

A 3000 MHz oscillator using a BFP520 transistor operating at 2V and 20mA. In this case, the capacitor C_2 needs to be replaced by an inductor L_3 which tunes out the collector emitter capacitance to achieve the optimum value. The 1nF on the left is a DC separation capacitor. This case is optimized for output power

Increasing the output power strongly reduces the phase noise

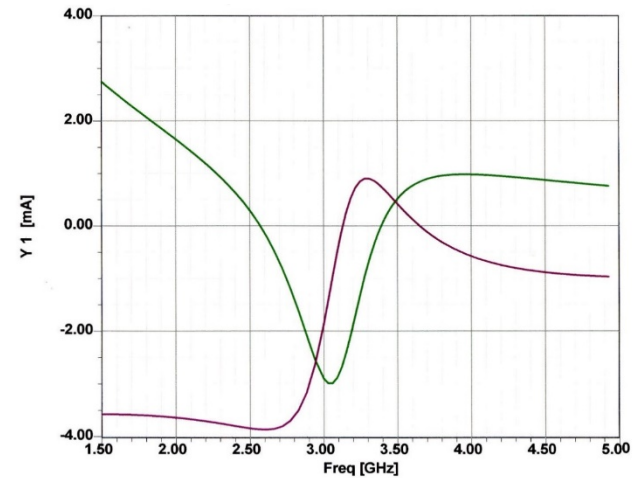

Shows the real and imaginary currents for oscillation. The reactive current crosses the zero line at 3120 MHz. This is close, but not exactly at the point of most negative resistance current. The reason for the shift of 120 MHz is due to the use of small-signal analysis rather than the large-signal analysis

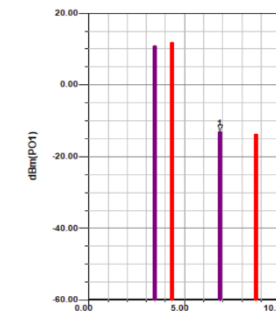
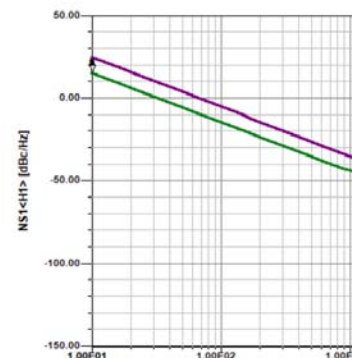

OUTLINE

- **Introduction**
- **What is an oscillator?**
- **Introduction to Microwave Oscillators and Their Mathematical Treatment**
- **Transistor Types**
- **Transistor models and Noise Contributions**
- **Linear Approach to the Calculation of Oscillator Phase Noise**
- **Typical Microwave Oscillator (Colpitts Oscillator)**
- **Designing an Oscillator**
- **Tuning Diode Noise Contribution**
- **Designing an Oscillator based on Linear S-Parameters**
- **Large signal Operation of Oscillators (Colpitts/YIG)**
- **Classical Linear Two-Port Oscillator Design**
- **Microwave Resonators**
- **A Novel Tunable Active Spiral Inductor**
- **The Active Inductor Using a Gyrator**
- **INTRODUCTION: Active Inductor Oscillator**
- **Synthesized Inductor Circuits**
- **Phase Noise Contribution of the Various Parts of the Oscillator Using an Active Inductor**
- **The Modern Time-Domain Behavior of an Oscillator**
- **Test Case: Design Example of a 100MHz crystal oscillator**
- **Phase Noise Analysis Based on the Negative Resistance Model**
- **Oscillator Phase Noise**
- **Design Examples of Oscillators for Best Phase Noise and Good Output Power**
- **Phase Noise of the integrated CMOS oscillator**
- **Appendix: A Solution for Calculating Phase Noise in Oscillators**
 - **Oscillator Noise Models**
 - **Noise Generation in Oscillators**
- **Key References**

➤ LARGE SIGNAL OPERATION

- **Definition: RF voltages/currents are of similar magnitude as the DC values. Test points were $V_c = 2V, I_c = 20mA$.**
- **The transistor behaves differently under large signal conditions.**
- **Large signal parameters can be obtained from simulation using SPICE parameters, calculating the Bessel functions of the currents of the intrinsic transistor and adding the parasitics and measurements.**

This Figure shows the R&S VNA and the test fixture for the transistor of choice

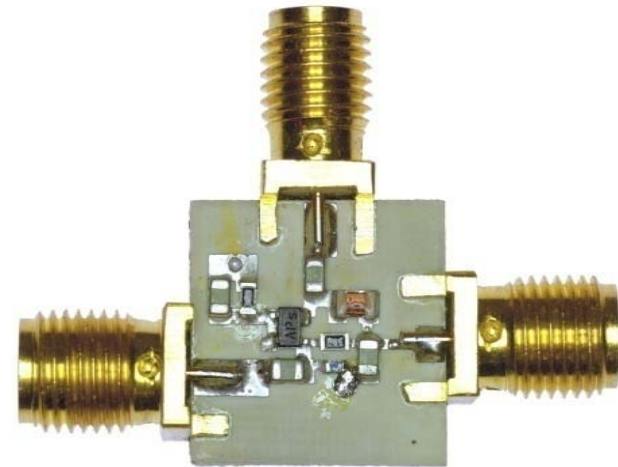
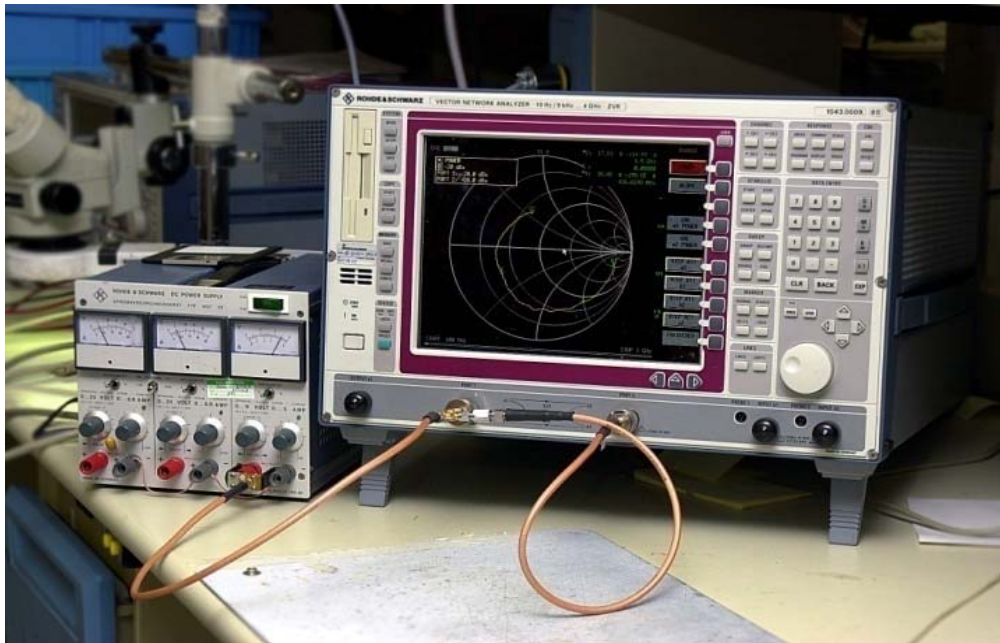

Typical measurement setup for evaluation of large signal parameters (R&S vector analyzer and the test fixture for the transistor of choice), Agilent now calls this X Parameters

➤ LARGE SIGNAL OPERATION , Cont'd.

The bias, drive level, and frequency dependent S parameters are then obtained for practical use

Measured large-signal S_{11} of the BFP520

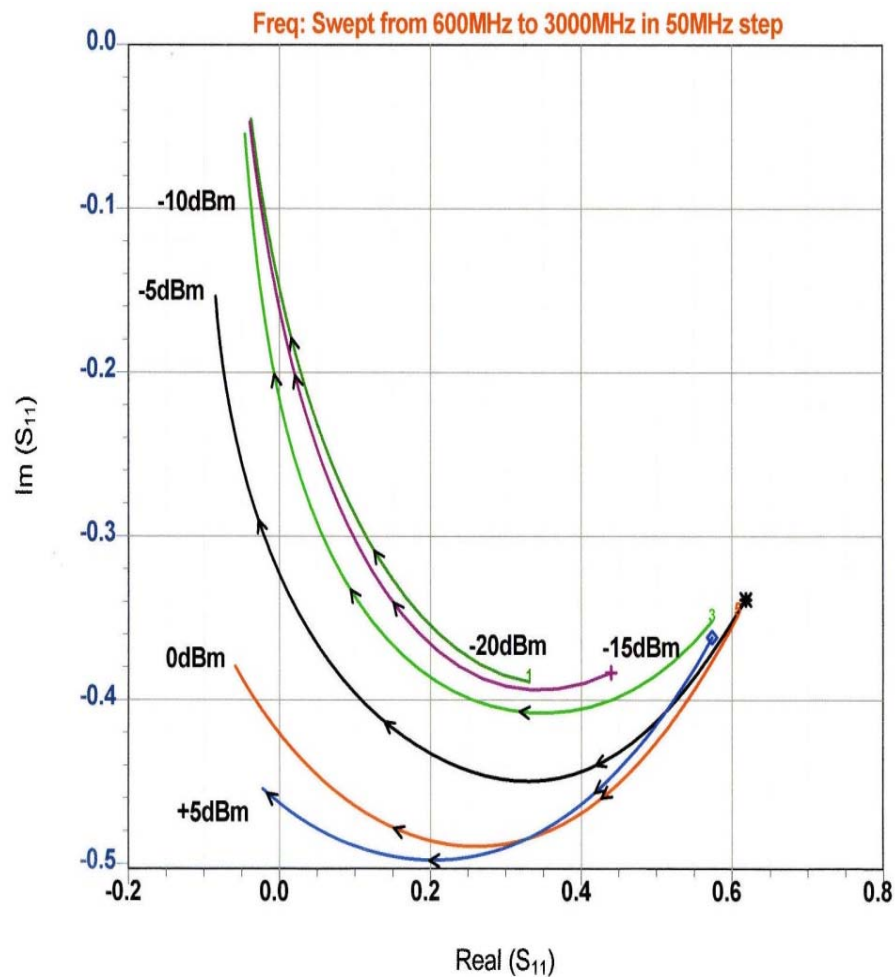

Measured large-signal S_{12} of the BFP520

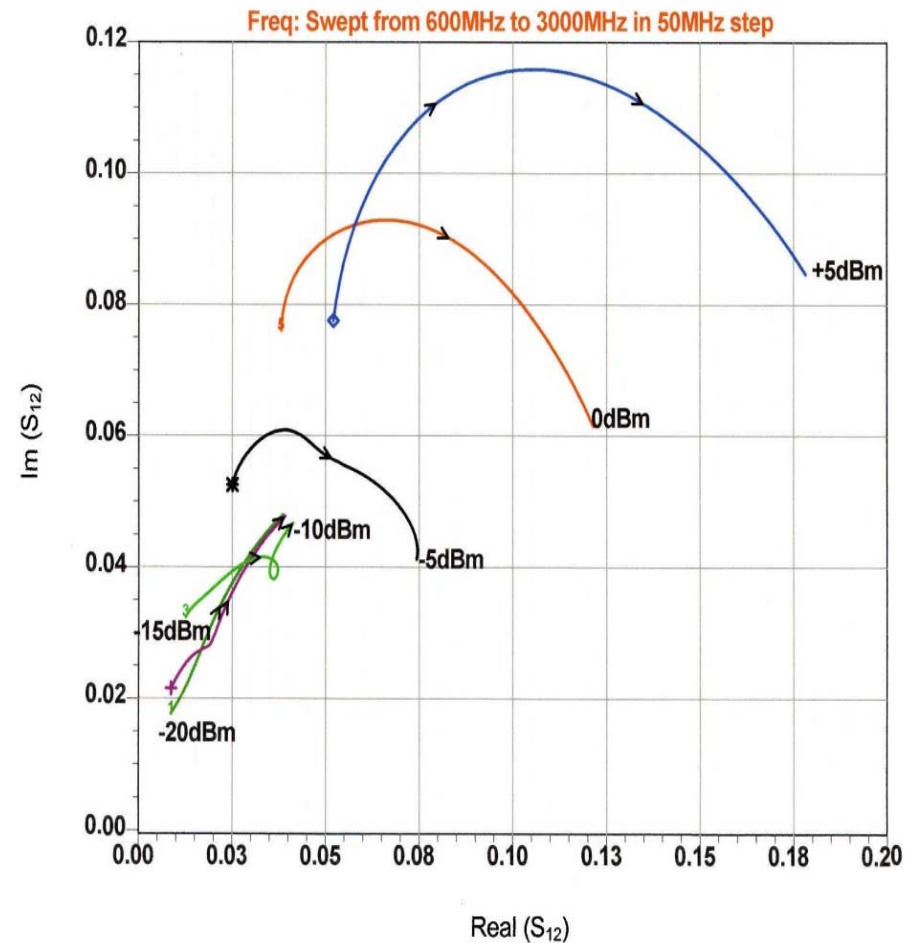

➤ LARGE SIGNAL OPERATION , Cont'd.

The bias, drive level, and frequency dependent S parameters are then obtained for practical use

Measured large-signal S_{21} of the BFP520

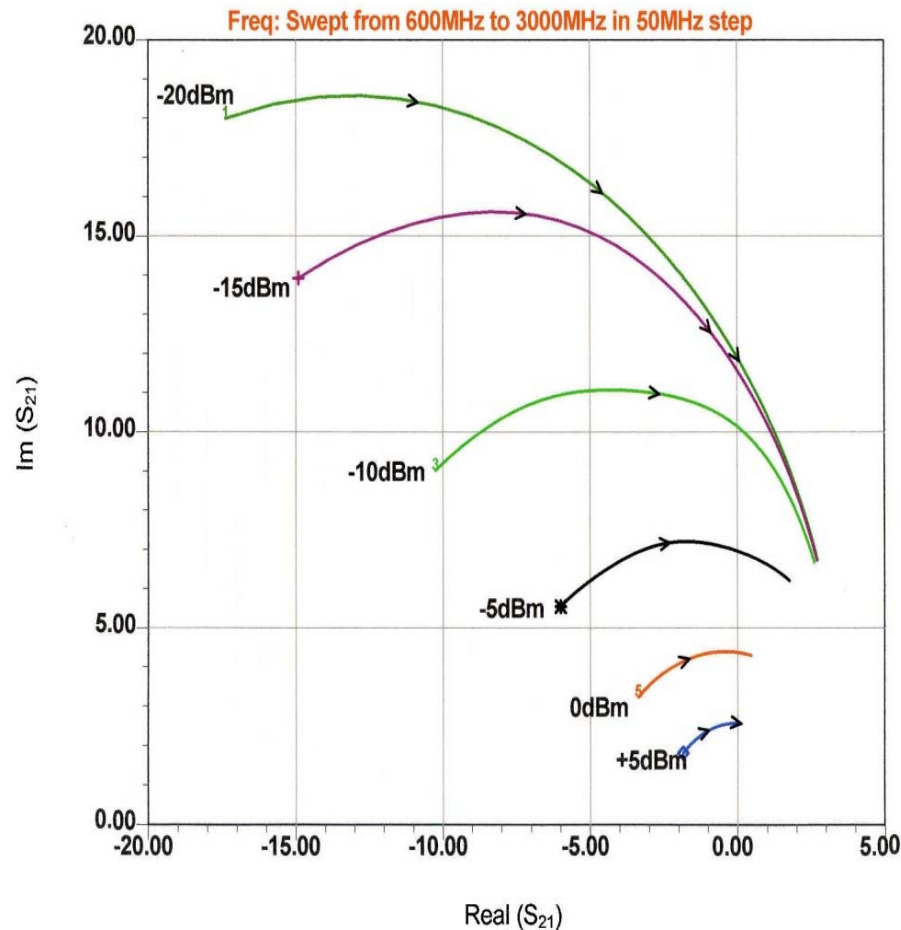

Measured large-signal S_{22} of the BFP520

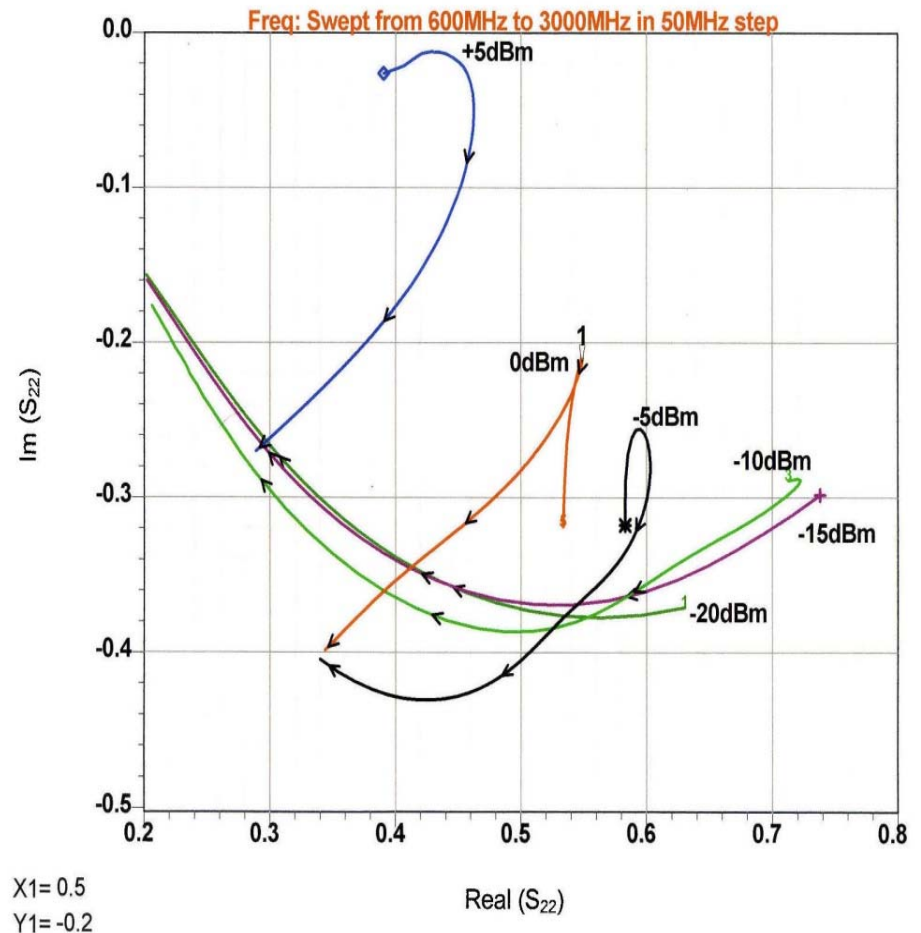

➤ LARGE SIGNAL OPERATION , Cont'd.

Typical transient simulation of a ceramic resonator-based high-Q, 1GHz oscillator (node of the voltage for display is taken from the emitter)

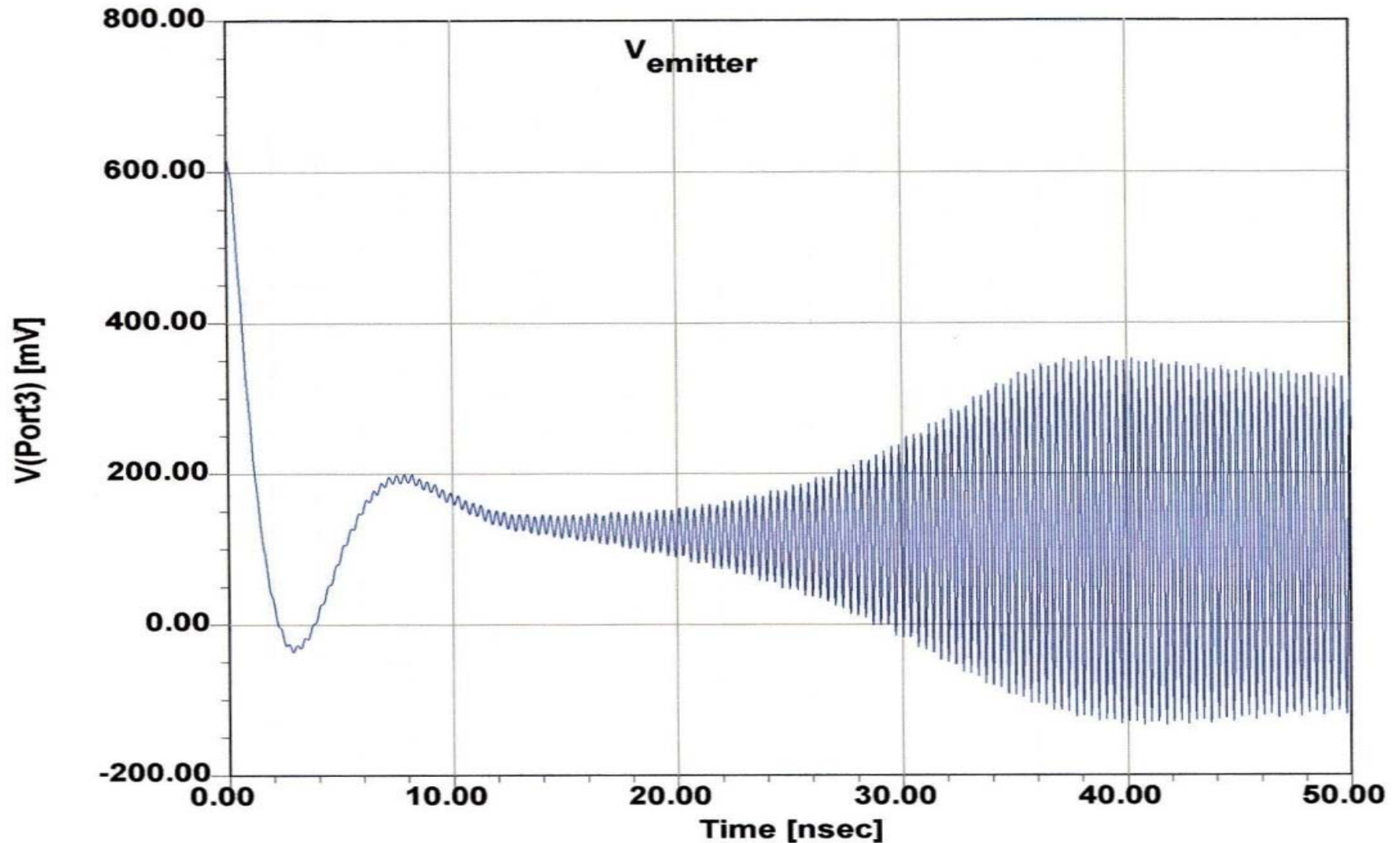

➤ LARGE SIGNAL OPERATION OF OSCILLATORS (COLPITTS/YIG)

Example: 3000 MHz YIG Oscillator

Series-Feedback Oscillator

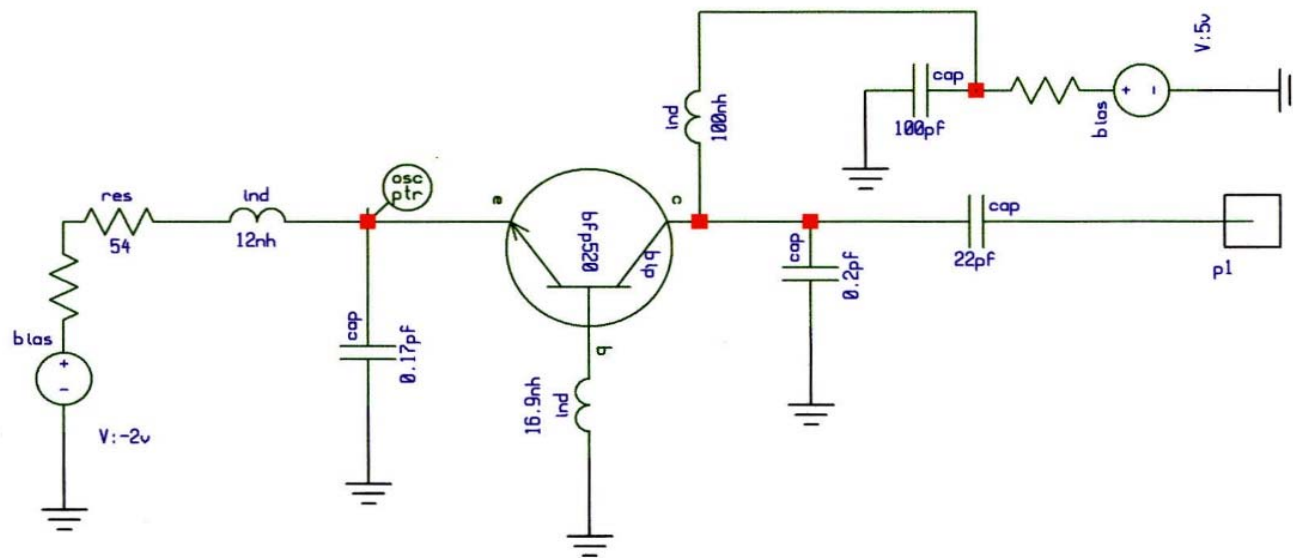

Series feedback oscillator: For oscillation condition, the base to ground inductance and the emitter to ground capacitance is required. The 12nH inductor acts a choke. The output is tuned and terminated into 50Ω

OUTLINE

- **Introduction**
- **What is an oscillator?**
- **Introduction to Microwave Oscillators and Their Mathematical Treatment**
- **Transistor Types**
- **Transistor models and Noise Contributions**
- **Linear Approach to the Calculation of Oscillator Phase Noise**
- **Typical Microwave Oscillator (Colpitts Oscillator)**
- **Designing an Oscillator**
- **Tuning Diode Noise Contribution**
- **Designing an Oscillator based on Linear S-Parameters**
- **Large signal Operation of Oscillators (Colpitts/YIG)**
- **Classical Linear Two-Port Oscillator Design**
- **Microwave Resonators**
- **A Novel Tunable Active Spiral Inductor**
- **The Active Inductor Using a Gyrator**
- **INTRODUCTION: Active Inductor Oscillator**
- **Synthesized Inductor Circuits**
- **Phase Noise Contribution of the Various Parts of the Oscillator Using an Active Inductor**
- **The Modern Time-Domain Behavior of an Oscillator**
- **Test Case: Design Example of a 100MHz crystal oscillator**
- **Phase Noise Analysis Based on the Negative Resistance Model**
- **Oscillator Phase Noise**
- **Design Examples of Oscillators for Best Phase Noise and Good Output Power**
- **Phase Noise of the integrated CMOS oscillator**
- **Appendix: A Solution for Calculating Phase Noise in Oscillators**
 - **Oscillator Noise Models**
 - **Noise Generation in Oscillators**
- **Key References**

➤ TUNING DIODE NOISE CONTRIBUTION

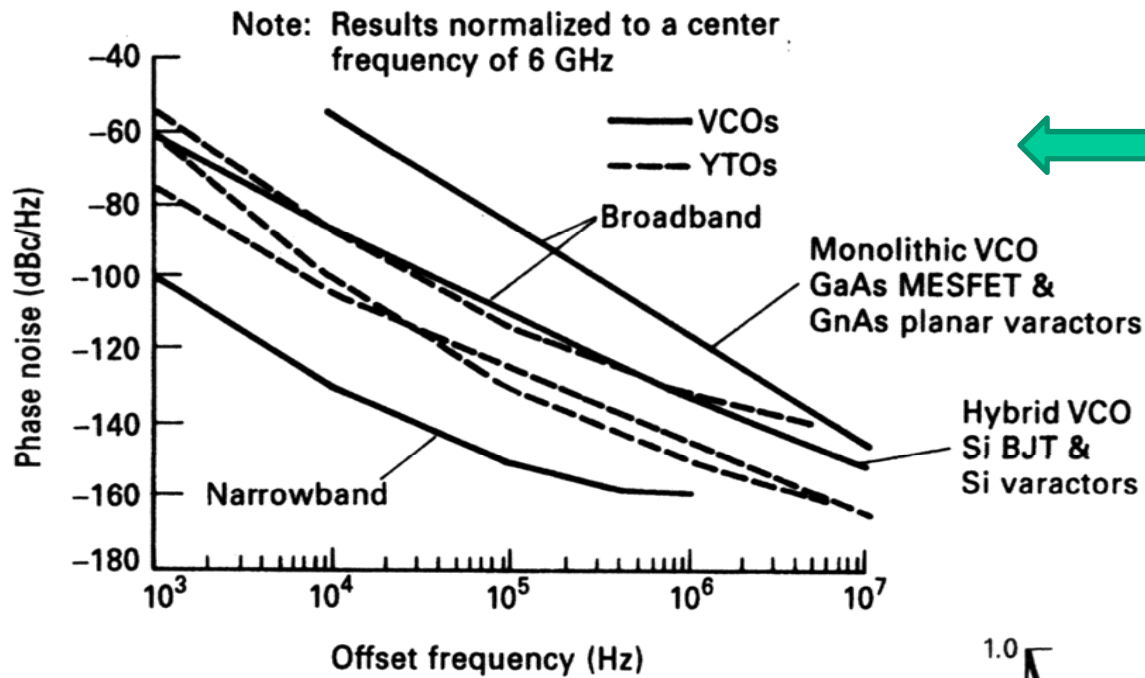

← Phase noise comparison of different YIG and varactor tuned oscillators

Varactor parameters: capacitance, equivalent resistor, and Q , as well as the magnitude of S_{11} , as a function of reverse voltage

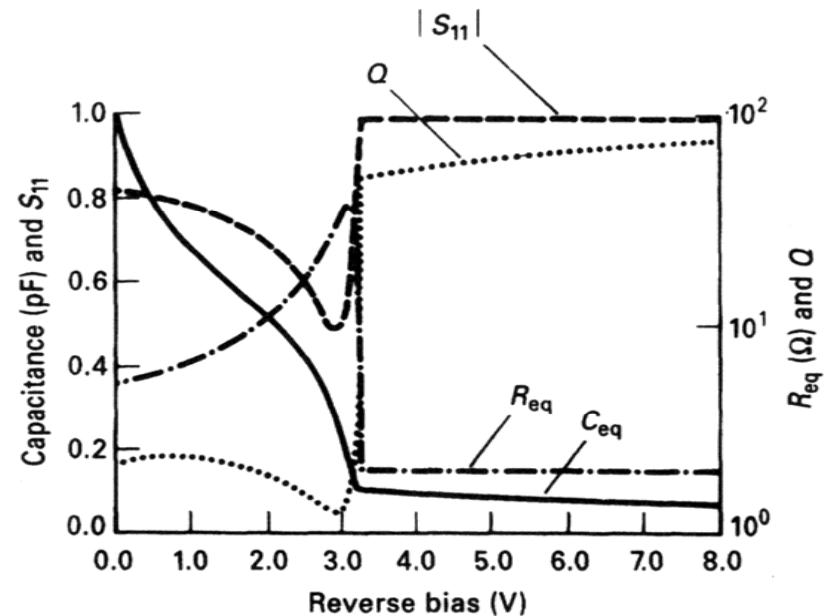

OUTLINE

- **Introduction**
- **What is an oscillator?**
- **Introduction to Microwave Oscillators and Their Mathematical Treatment**
- **Transistor Types**
- **Transistor models and Noise Contributions**
- **Linear Approach to the Calculation of Oscillator Phase Noise**
- **Typical Microwave Oscillator (Colpitts Oscillator)**
- **Designing an Oscillator**
- **Tuning Diode Noise Contribution**
- **Designing an Oscillator based on Linear S-Parameters**
- **Large signal Operation of Oscillators (Colpitts/YIG)**
- **Classical Linear Two-Port Oscillator Design**
- **Microwave Resonators**
- **A Novel Tunable Active Spiral Inductor**
- **The Active Inductor Using a Gyrator**
- **INTRODUCTION: Active Inductor Oscillator**
- **Synthesized Inductor Circuits**
- **Phase Noise Contribution of the Various Parts of the Oscillator Using an Active Inductor**
- **The Modern Time-Domain Behavior of an Oscillator**
- **Test Case: Design Example of a 100MHz crystal oscillator**
- **Phase Noise Analysis Based on the Negative Resistance Model**
- **Oscillator Phase Noise**
- **Design Examples of Oscillators for Best Phase Noise and Good Output Power**
- **Phase Noise of the integrated CMOS oscillator**
- **Appendix: A Solution for Calculating Phase Noise in Oscillators**
 - **Oscillator Noise Models**
 - **Noise Generation in Oscillators**
- **Key References**

➤ CLASSICAL LINEAR TWO-PORT OSCILLATOR DESIGN

Oscillator design flowchart.

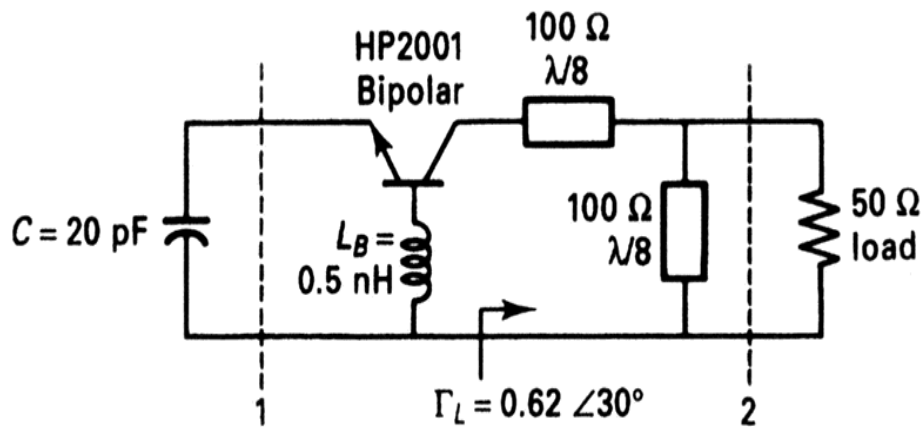
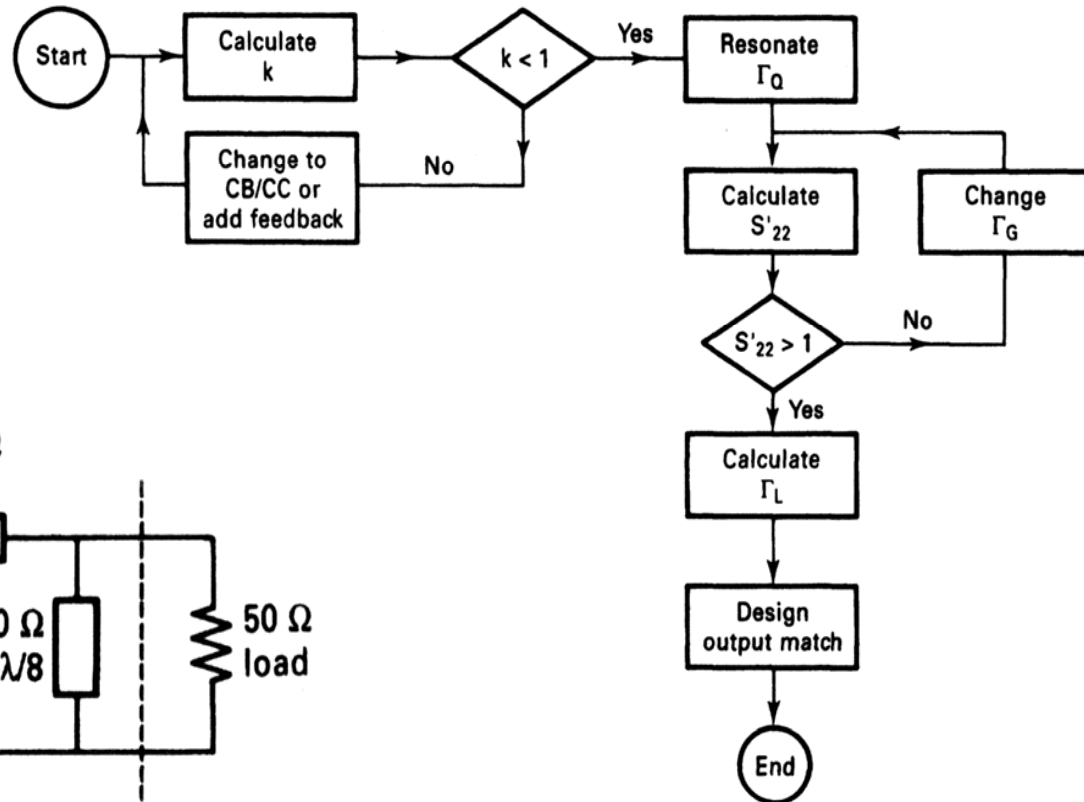

Two Port Oscillator example at 2 GHz

OUTLINE

- **Introduction**
- **What is an oscillator?**
- **Introduction to Microwave Oscillators and Their Mathematical Treatment**
- **Transistor Types**
- **Transistor models and Noise Contributions**
- **Linear Approach to the Calculation of Oscillator Phase Noise**
- **Typical Microwave Oscillator (Colpitts Oscillator)**
- **Designing an Oscillator**
- **Tuning Diode Noise Contribution**
- **Designing an Oscillator based on Linear S-Parameters**
- **Large signal Operation of Oscillators (Colpitts/YIG)**
- **Classical Linear Two-Port Oscillator Design**
- **Microwave Resonators**
- **A Novel Tunable Active Spiral Inductor**
- **The Active Inductor Using a Gyrator**
- **INTRODUCTION: Active Inductor Oscillator**
- **Synthesized Inductor Circuits**
- **Phase Noise Contribution of the Various Parts of the Oscillator Using an Active Inductor**
- **The Modern Time-Domain Behavior of an Oscillator**
- **Test Case: Design Example of a 100MHz crystal oscillator**
- **Phase Noise Analysis Based on the Negative Resistance Model**
- **Oscillator Phase Noise**
- **Design Examples of Oscillators for Best Phase Noise and Good Output Power**
- **Phase Noise of the integrated CMOS oscillator**
- **Appendix: A Solution for Calculating Phase Noise in Oscillators**
 - **Oscillator Noise Models**
 - **Noise Generation in Oscillators**
- **Key References**

➤ MICROWAVE RESONATORS

SAW Surface Acoustic Wave Oscillators

DRO Dielectric Resonator-based Oscillators

YIG Oscillators

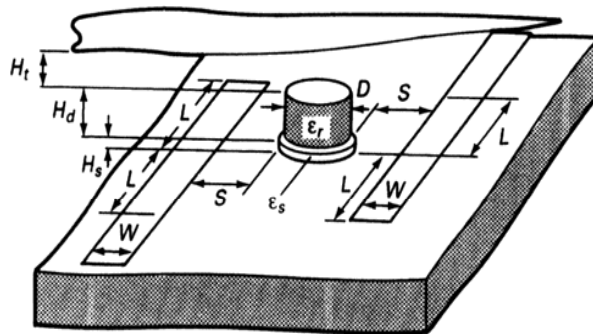

Usually $L = \frac{\lambda_g}{4}$

*DRO on microstrip
as Bandpass filter*

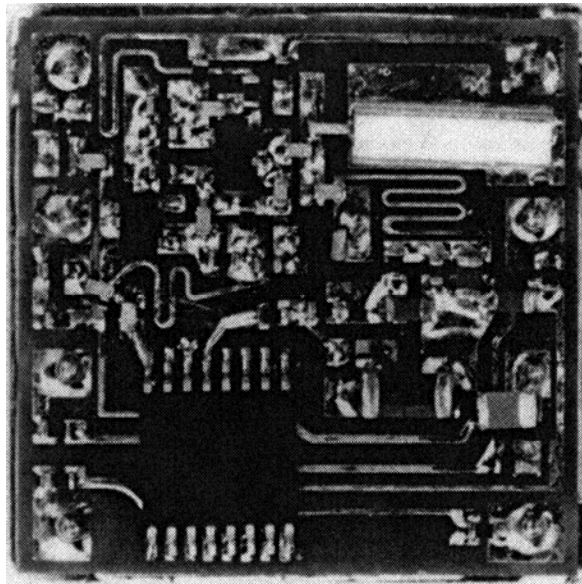

*Ceramic
Resonator
Oscillator*

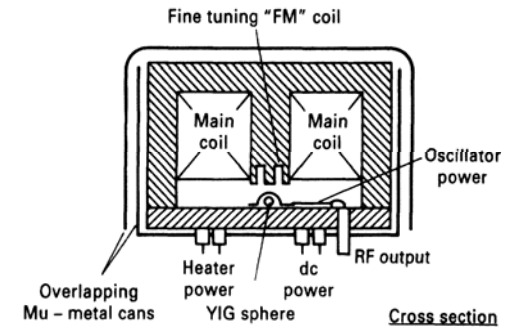
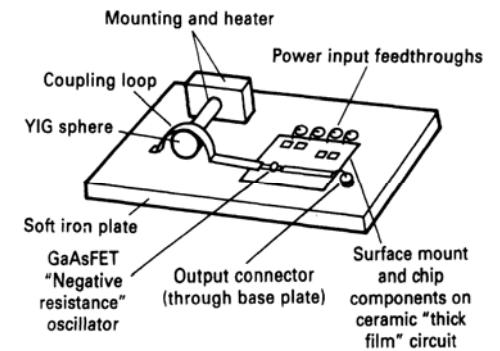

*The yttrium-iron-garnet
(YIG) sphere serves as the
resonator in the sweep
oscillators used in many
spectrum analyzers*

OUTLINE

- **Introduction**
- **What is an oscillator?**
- **Introduction to Microwave Oscillators and Their Mathematical Treatment**
- **Transistor Types**
- **Transistor models and Noise Contributions**
- **Linear Approach to the Calculation of Oscillator Phase Noise**
- **Typical Microwave Oscillator (Colpitts Oscillator)**
- **Designing an Oscillator**
- **Tuning Diode Noise Contribution**
- **Designing an Oscillator based on Linear S-Parameters**
- **Large signal Operation of Oscillators (Colpitts/YIG)**
- **Classical Linear Two-Port Oscillator Design**
- **Microwave Resonators**
- **A Novel Tunable Active Spiral Inductor**
- **The Active Inductor Using a Gyrator**
- **INTRODUCTION: Active Inductor Oscillator**
- **Synthesized Inductor Circuits**
- **Phase Noise Contribution of the Various Parts of the Oscillator Using an Active Inductor**
- **The Modern Time-Domain Behavior of an Oscillator**
- **Test Case: Design Example of a 100MHz crystal oscillator**
- **Phase Noise Analysis Based on the Negative Resistance Model**
- **Oscillator Phase Noise**
- **Design Examples of Oscillators for Best Phase Noise and Good Output Power**
- **Phase Noise of the integrated CMOS oscillator**
- **Appendix: A Solution for Calculating Phase Noise in Oscillators**
 - **Oscillator Noise Models**
 - **Noise Generation in Oscillators**
- **Key References**

➤ INTRODUCTION OF THE SPIRAL INDUCTOR

➤ A NOVEL TUNABLE ACTIVE SPIRAL INDUCTOR

A typical sketch of spiral inductor

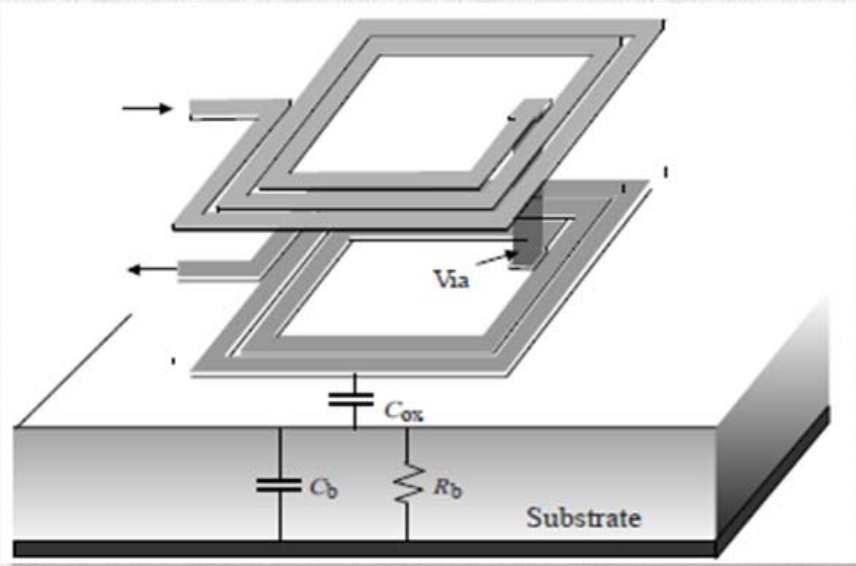

A lumped model of spiral inductor

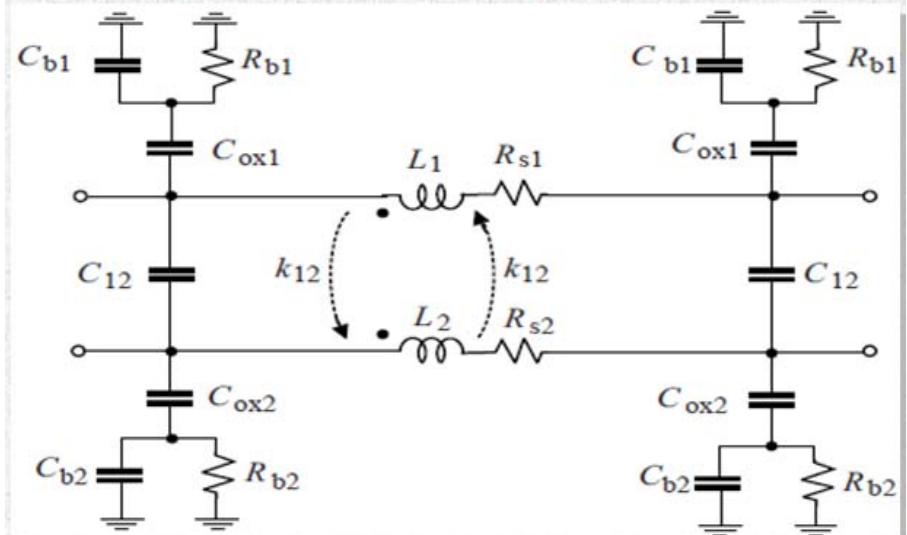

➤ PASSIVE SPIRAL INDUCTOR BEHAVIOUR

On-Chip Spiral Inductor

N= 3 turns
W=15 μm
S= 20 μm ,
Ri=200 μm

On-Chip Inductor
requires large dies
area: Not a
Cost-Effective
Solutions !!!

EM Simulated Current

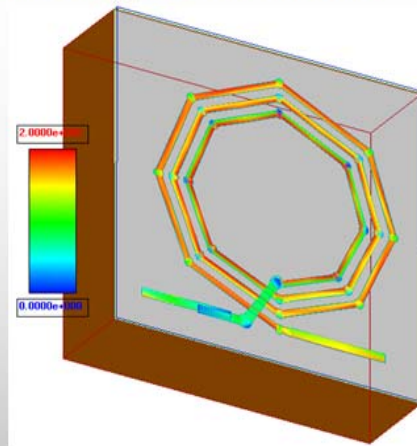

EM Simulated S-Parameters

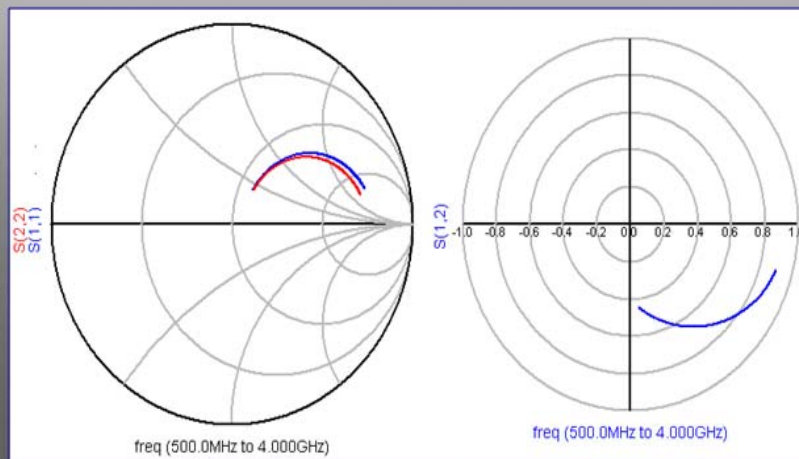

The agreement between the measured S-parameter based and EM-Simulated values is extremely good. However, the physical size of the chip inductor requires a large die area, thus not a cost-effective solution

OUTLINE

- **Introduction**
- **What is an oscillator?**
- **Introduction to Microwave Oscillators and Their Mathematical Treatment**
- **Transistor Types**
- **Transistor models and Noise Contributions**
- **Linear Approach to the Calculation of Oscillator Phase Noise**
- **Typical Microwave Oscillator (Colpitts Oscillator)**
- **Designing an Oscillator**
- **Tuning Diode Noise Contribution**
- **Designing an Oscillator based on Linear S-Parameters**
- **Large signal Operation of Oscillators (Colpitts/YIG)**
- **Classical Linear Two-Port Oscillator Design**
- **Microwave Resonators**
- **A Novel Tunable Active Spiral Inductor**
- **The Active Inductor Using a Gyrator**
- **INTRODUCTION: Active Inductor Oscillator**
- **Synthesized Inductor Circuits**
- **Phase Noise Contribution of the Various Parts of the Oscillator Using an Active Inductor**
- **The Modern Time-Domain Behavior of an Oscillator**
- **Test Case: Design Example of a 100MHz crystal oscillator**
- **Phase Noise Analysis Based on the Negative Resistance Model**
- **Oscillator Phase Noise**
- **Design Examples of Oscillators for Best Phase Noise and Good Output Power**
- **Phase Noise of the integrated CMOS oscillator**
- **Appendix: A Solution for Calculating Phase Noise in Oscillators**
 - **Oscillator Noise Models**
 - **Noise Generation in Oscillators**
- **Key References**

➤ THE ACTIVE INDUCTOR USING A GYRATOR

B. D. H. Tellegen of Philips Research Laboratory proposed a new 2-port network element, a Gyrator in 1948, which exhibits a immittance conversion property, needed to generate an synthesized active inductor using transistors.

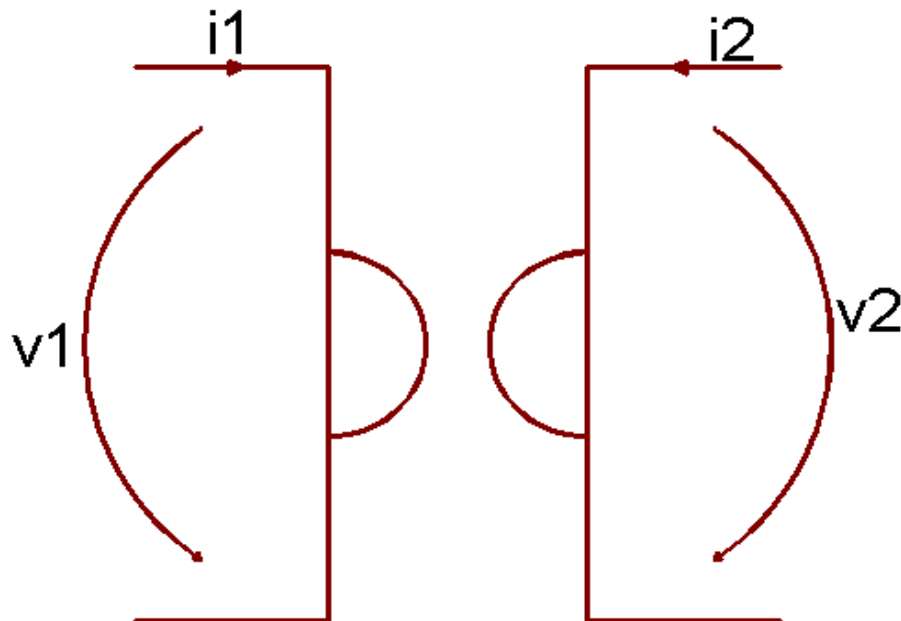

$$\begin{bmatrix} i_1 \\ i_2 \end{bmatrix} = \begin{bmatrix} 0 & g \\ -g & 0 \end{bmatrix} \begin{bmatrix} v_1 \\ v_2 \end{bmatrix}$$

Where 'g' is called gyration capacitance

An admittance Y connected to the secondary terminals is converted to its dual g^2/Y , this phenomena is called immittance conversion, C transforms into L, parallel tuned circuit into series tuned circuit

➤ ACTIVE INDUCTOR USING GYRATOR

Tunable Active Inductor (TAI)

- ✓ Integrable and Compact
- ✓ Cost-Effective
- ✓ Power-Efficient Solutions

TAI: Design Challenges

- ✓ High Power Consumption
- ✓ Noise Figure & Instability
- ✓ Low Dynamic Ranges

TAI using Gyrator

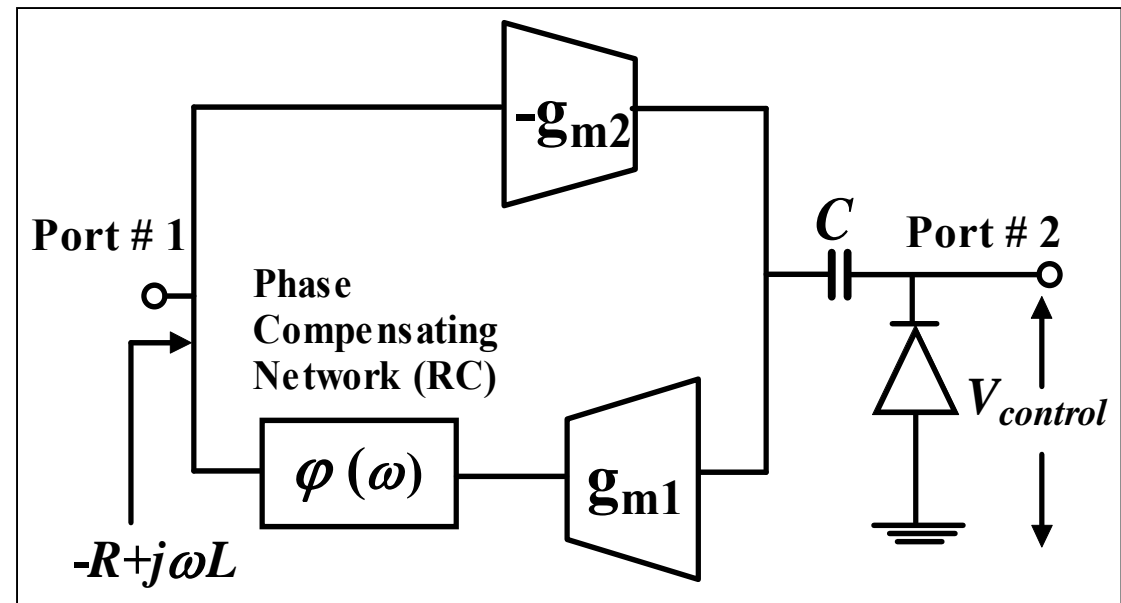

Phase shift network $\varphi(\omega)$ is required in TAI topology for suppressing the higher order modes and self oscillation

OUTLINE

- **Introduction**
- **What is an oscillator?**
- **Introduction to Microwave Oscillators and Their Mathematical Treatment**
- **Transistor Types**
- **Transistor models and Noise Contributions**
- **Linear Approach to the Calculation of Oscillator Phase Noise**
- **Typical Microwave Oscillator (Colpitts Oscillator)**
- **Designing an Oscillator**
- **Tuning Diode Noise Contribution**
- **Designing an Oscillator based on Linear S-Parameters**
- **Large signal Operation of Oscillators (Colpitts/YIG)**
- **Classical Linear Two-Port Oscillator Design**
- **Microwave Resonators**
- **A Novel Tunable Active Spiral Inductor**
- **The Active Inductor Using a Gyrator**
- **INTRODUCTION: Active Inductor Oscillator**
- **Synthesized Inductor Circuits**
- **Phase Noise Contribution of the Various Parts of the Oscillator Using an Active Inductor**
- **The Modern Time-Domain Behavior of an Oscillator**
- **Test Case: Design Example of a 100MHz crystal oscillator**
- **Phase Noise Analysis Based on the Negative Resistance Model**
- **Oscillator Phase Noise**
- **Design Examples of Oscillators for Best Phase Noise and Good Output Power**
- **Phase Noise of the integrated CMOS oscillator**
- **Appendix: A Solution for Calculating Phase Noise in Oscillators**
 - **Oscillator Noise Models**
 - **Noise Generation in Oscillators**
- **Key References**

➤ INTRODUCTION: ACTIVE INDUCTOR OSCILLATOR

This Figure shows the typical Active Inductor Oscillator (AIO), includes a stable active inductor within a conventional integrated LC oscillator

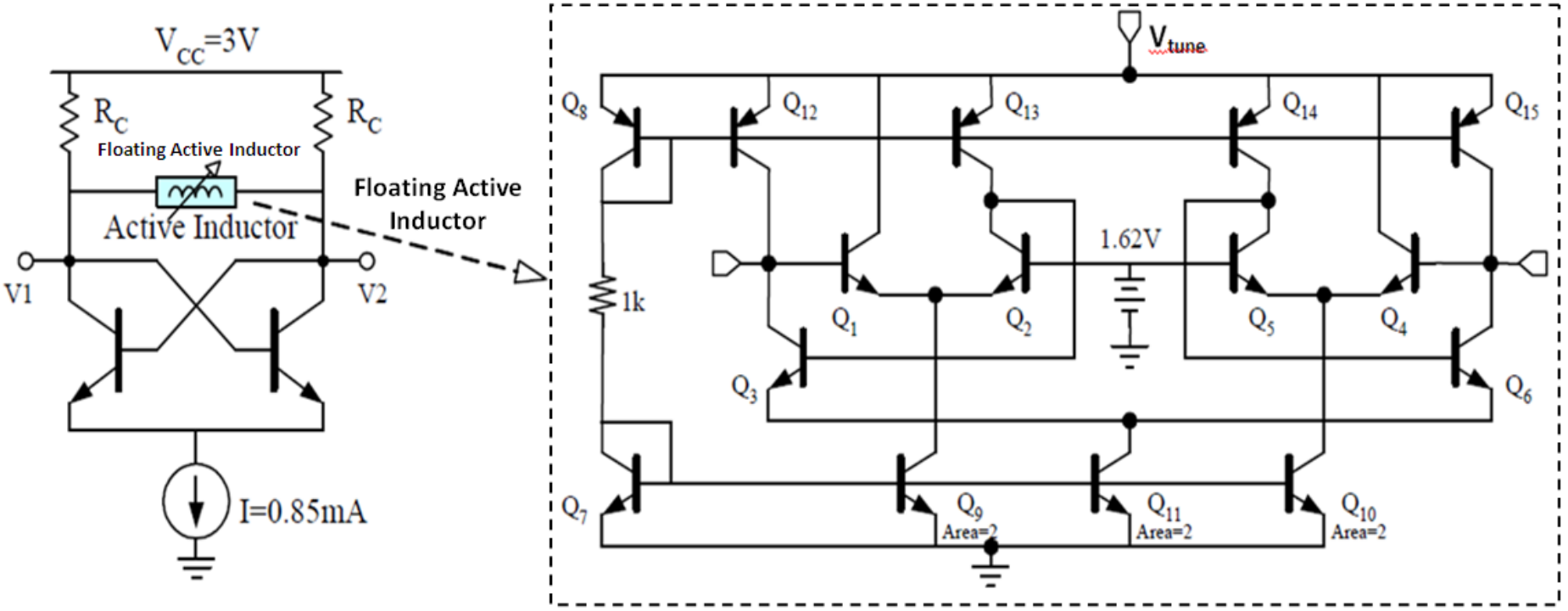

OUTLINE

- **Introduction**
- **What is an oscillator?**
- **Introduction to Microwave Oscillators and Their Mathematical Treatment**
- **Transistor Types**
- **Transistor models and Noise Contributions**
- **Linear Approach to the Calculation of Oscillator Phase Noise**
- **Typical Microwave Oscillator (Colpitts Oscillator)**
- **Designing an Oscillator**
- **Tuning Diode Noise Contribution**
- **Designing an Oscillator based on Linear S-Parameters**
- **Large signal Operation of Oscillators (Colpitts/YIG)**
- **Classical Linear Two-Port Oscillator Design**
- **Microwave Resonators**
- **A Novel Tunable Active Spiral Inductor**
- **The Active Inductor Using a Gyrator**
- **INTRODUCTION: Active Inductor Oscillator**
- **Synthesized Inductor Circuits**
- **Phase Noise Contribution of the Various Parts of the Oscillator Using an Active Inductor**
- **The Modern Time-Domain Behavior of an Oscillator**
- **Test Case: Design Example of a 100MHz crystal oscillator**
- **Phase Noise Analysis Based on the Negative Resistance Model**
- **Oscillator Phase Noise**
- **Design Examples of Oscillators for Best Phase Noise and Good Output Power**
- **Phase Noise of the integrated CMOS oscillator**
- **Appendix: A Solution for Calculating Phase Noise in Oscillators**
 - **Oscillator Noise Models**
 - **Noise Generation in Oscillators**
- **Key References**

➤ SYNTHESIZED INDUCTOR BEHAVIOUR

Typical Schematic of Synthesized Inductor

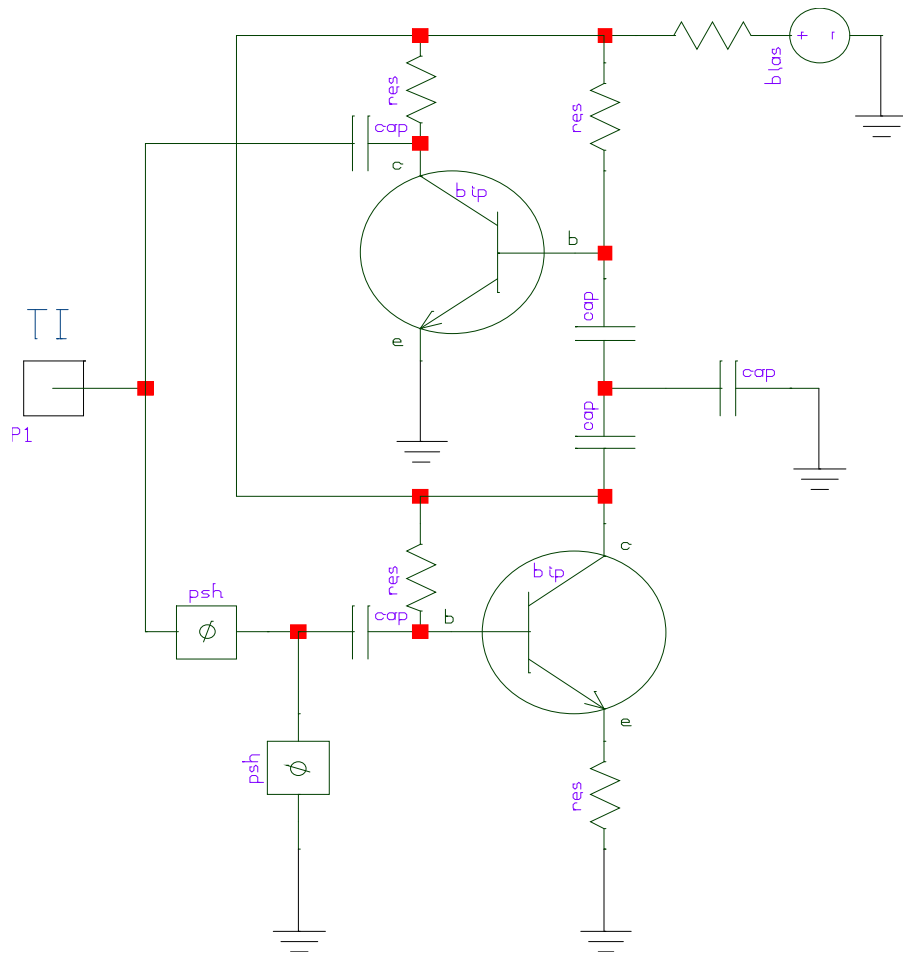

Impedance Plot

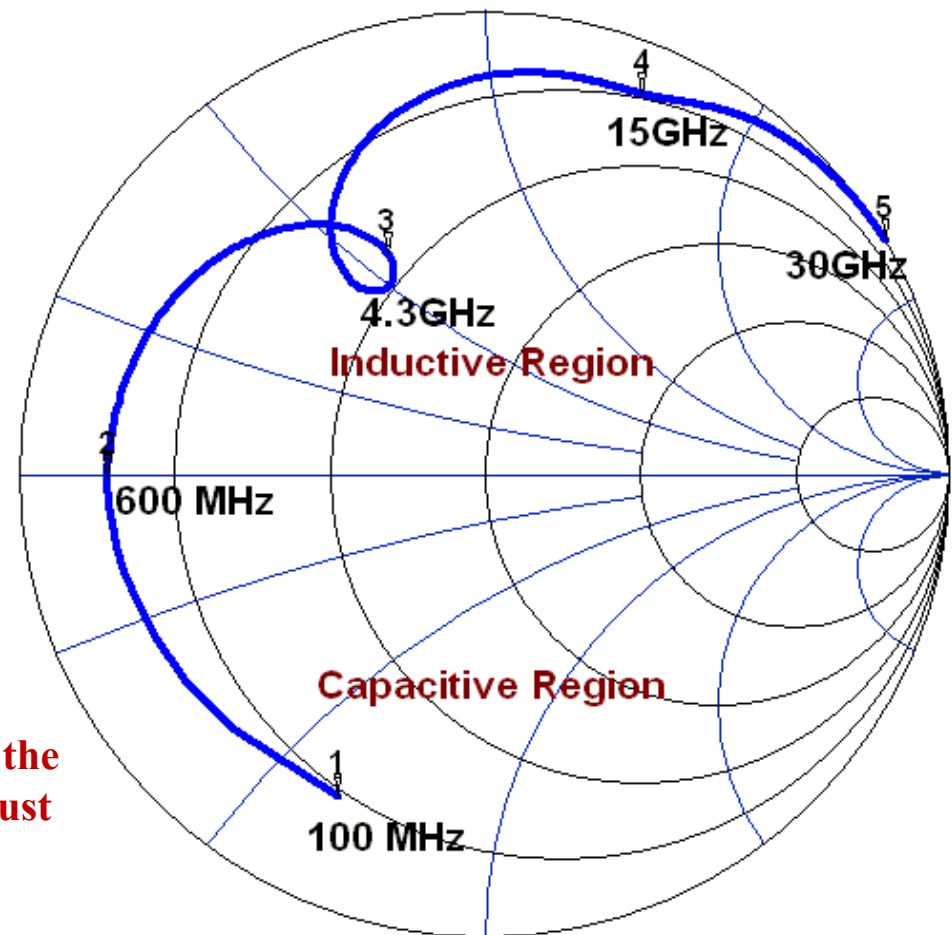

Impedance plot reveals the inductive behavior of the circuit from 600MHz (#2) to 30GHz (#5). Care must be taken to avoid the encircling and crossing at 4.3GHz (#3), which limits the applications.

➤ LAYOUT OF OSCILLATOR USING SPIRAL INDUCTOR

- Why use an Active Inductor instead of a Spiral Inductor?

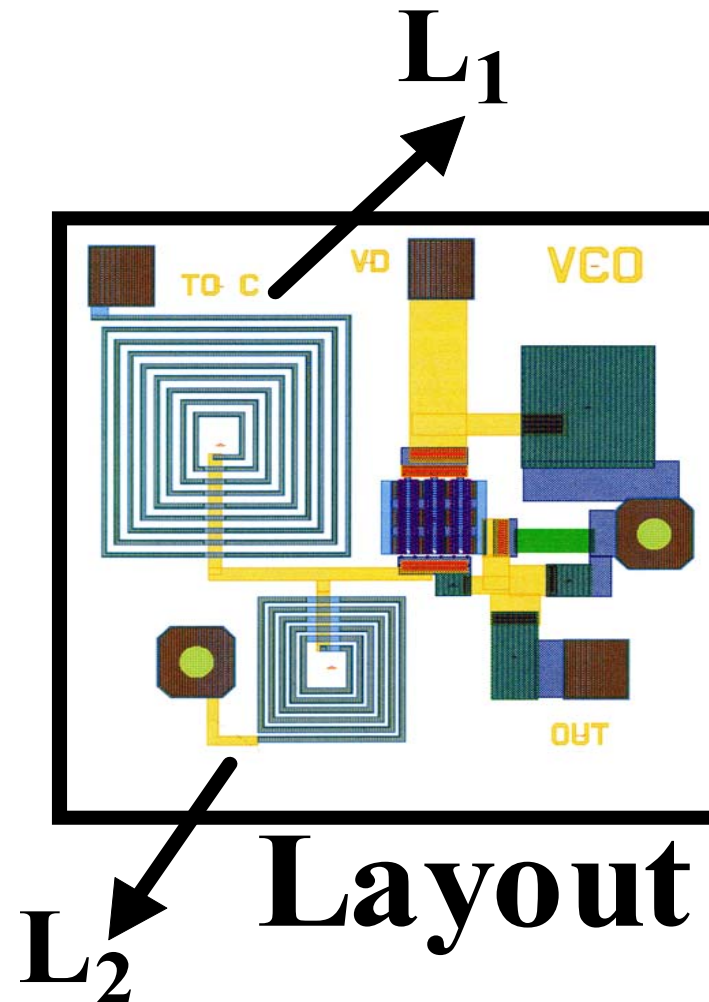

Physical size of spiral inductor

➤ PHYSICAL SIZE OF SPIRAL INDUCTOR

Physical size of spiral inductor

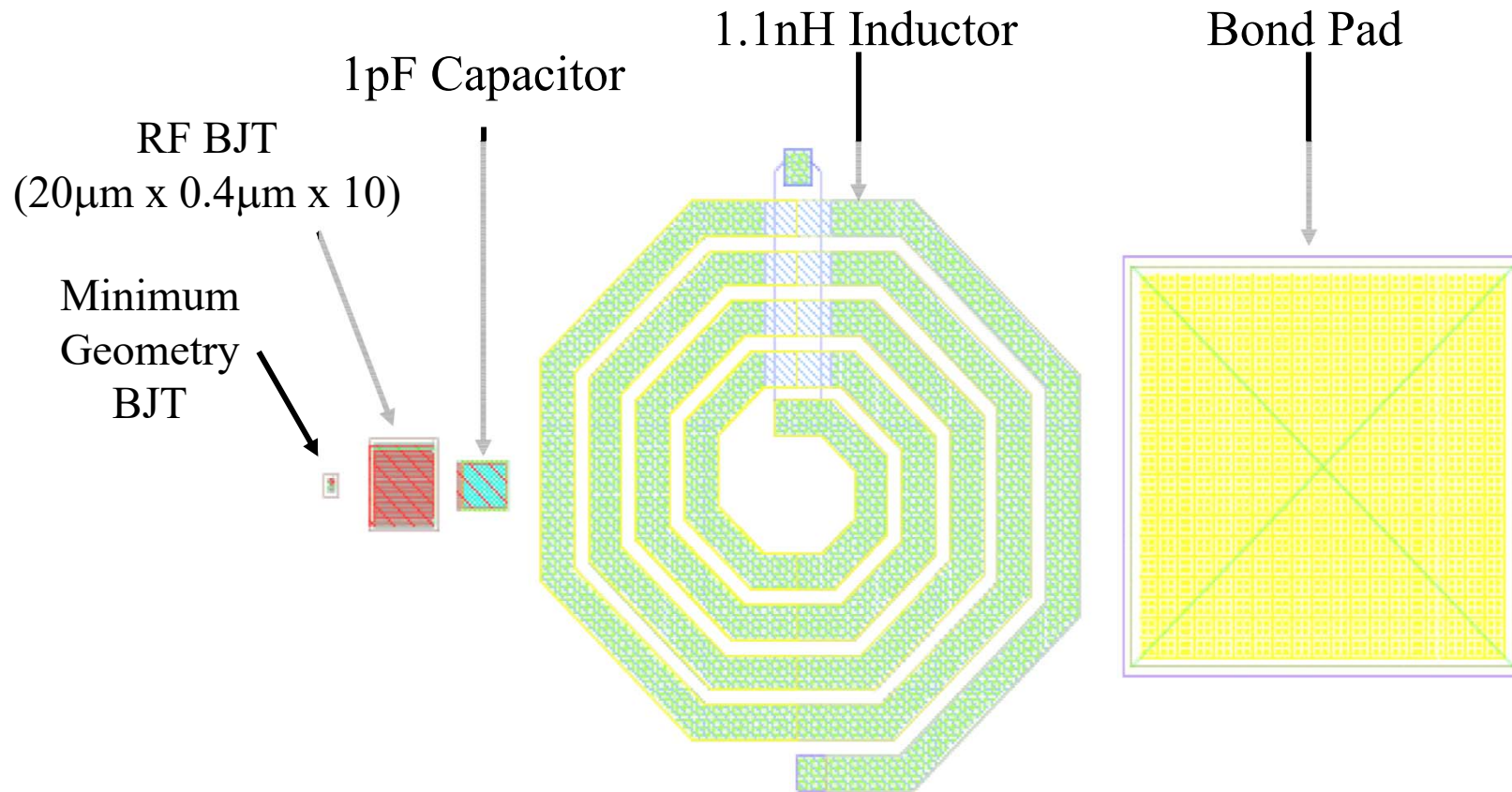

Why we avoid the use of on-chip inductors!

➤ ACTIVE INDUCTOR OSCILLATOR PHASE NOISE

Phase Noise Plots

Surface of phase noise @ 1MHz offset from the carrier

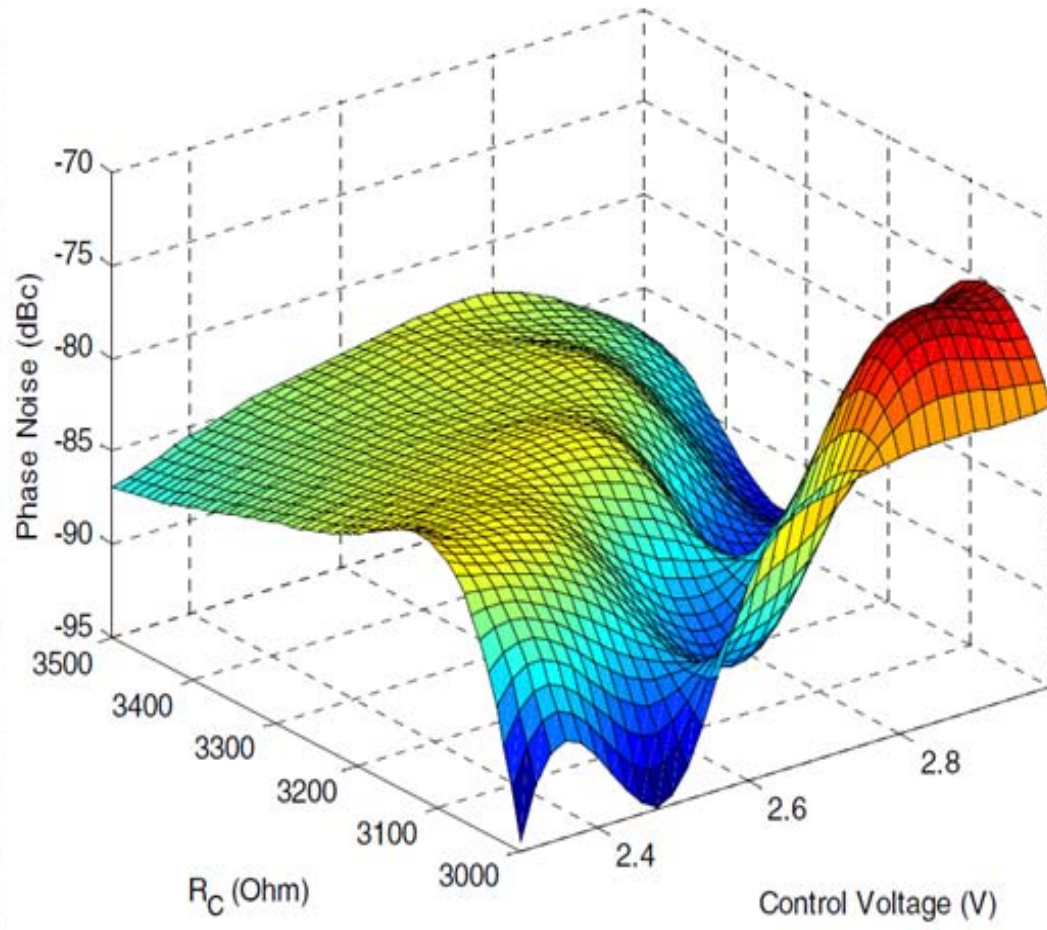

Advantages:

1. Broadband VCO Operation (Tuned L)
2. Multi-Band VCO Operation (Switched L)

Drawbacks:

1. DC Power Consumption
2. Poor Phase Noise Performances
3. Limited Large Signal Performances

➤ **Phase Noise Contribution of The Various Parts of the Oscillator Using an Active Inductor**

➤ SYNTHESIZED INDUCTOR CIRCUITS

SIMULATED TUNABLE INDUCTOR USING SiGe HBT DEVICE

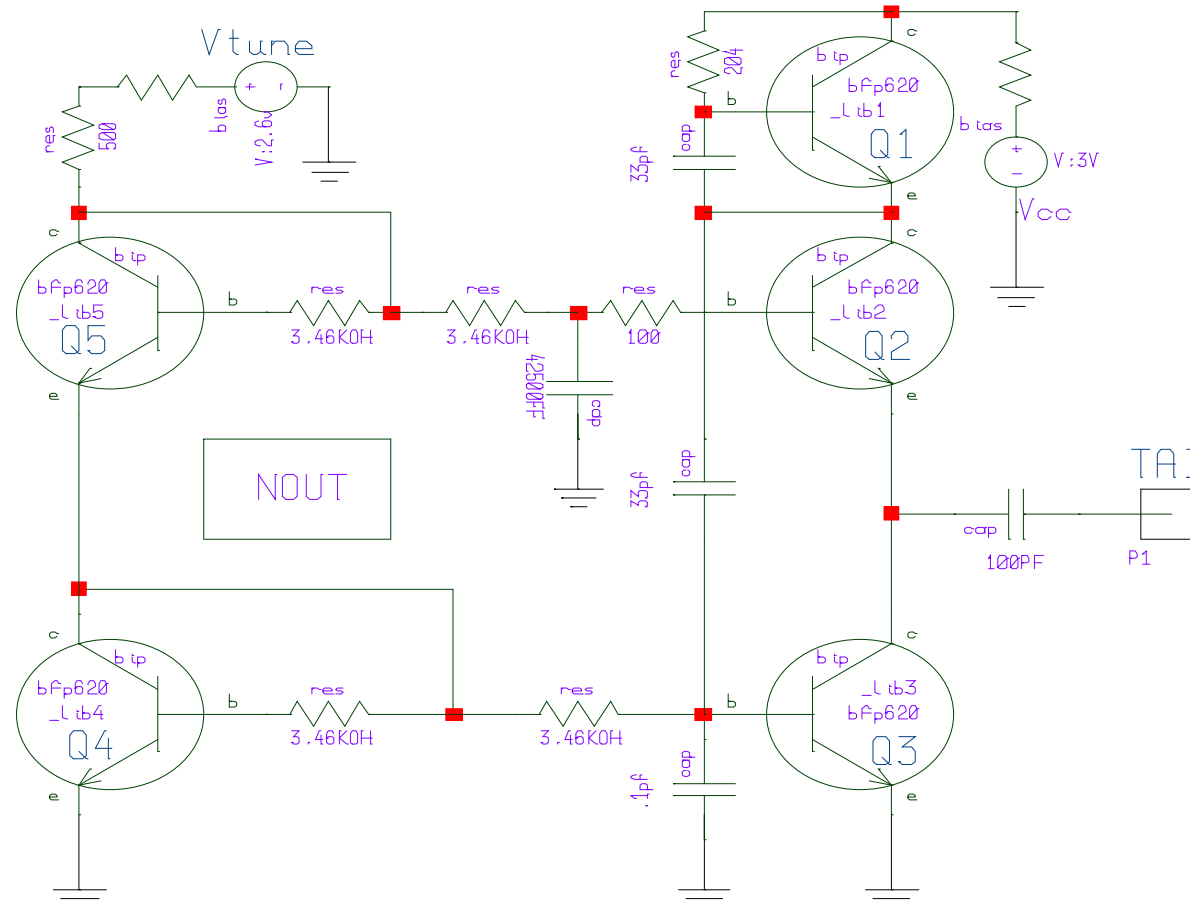

This Figure shows a schematic of a transistorized inductor using SiGe HBT (BFP 620) from Infineon . The reason for using a high cut-off frequency ($f_t=75$ GHz) SiGe HBT transistor is to minimize the package parasitic effects and allow comparative evaluations of the 1.9 GHz varactor-tuned and synthesized inductor-tuned LC oscillator using discrete components for experimental validations.

➤ COMPARISON: PASSIVE & ACTIVE INDUCTOR

Passive and Active Inductors

Performances	Passive Inductor (Spiral)	Active Inductor (Simulated: Active Device)
Q-factor	Low Q: Q-factor can be improved by differential method but added cost	High Q: active inductor offers higher Q than the passive spiral inductor
Tunability	Fixed/Limited	Large tuning range
Die-Area	Large die-area	Small die-area
Power-Consumption	Zero	Significant: consumes power for generating active inductance, resulting to high Q that may offsets the power consumptions
Linearity	Good Linearity $Z = j\omega L$	Poor Linearity: driven under large-signal condition, causing shift in operating point, distortions, and impedance fluctuations
Noise	Superior: good phase noise performance	Poor : poor phase noise performance
EMI	Significant: Due to EM coupling in spiral inductors	EMI insensitive
Floor-Planning	Poor: large die- area makes difficult floor-planning	Not required

➤ FREQUENCY VARIATION OF THE OSCILLATOR

Typical Schematic of Switched Mode and VCO Circuit

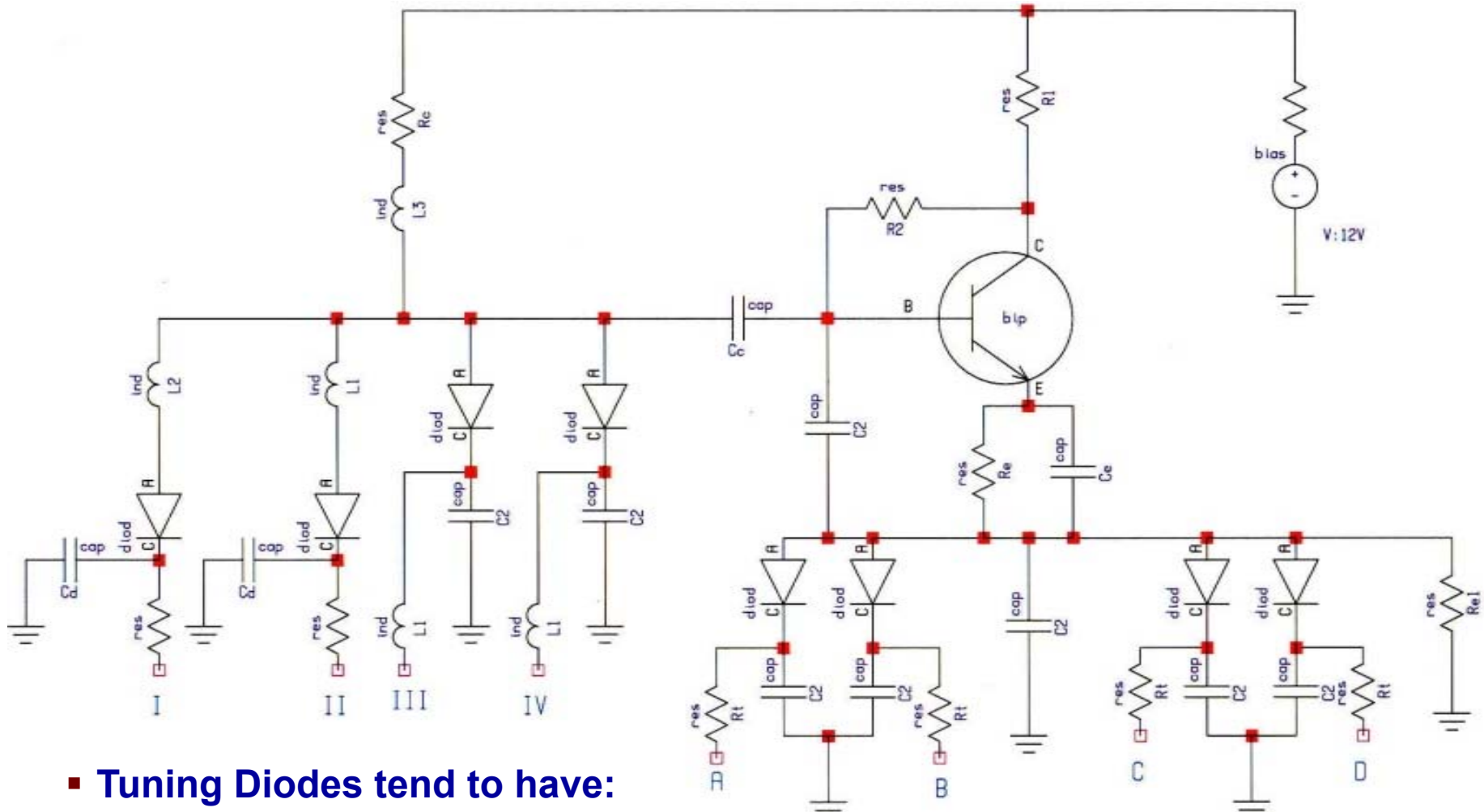

- **Tuning Diodes tend to have:**
 - Low Q at RF & MW frequencies
 - Limits Tunability Due to Package Parasitic
 - Changes characteristics due to low SRF
- **Active Tunable Inductor ATIs can overcome the above difficulties**

➤ NOISE SOURCES IN THE OSCILLATOR

Noise sources of oscillators being mixed on the carrier

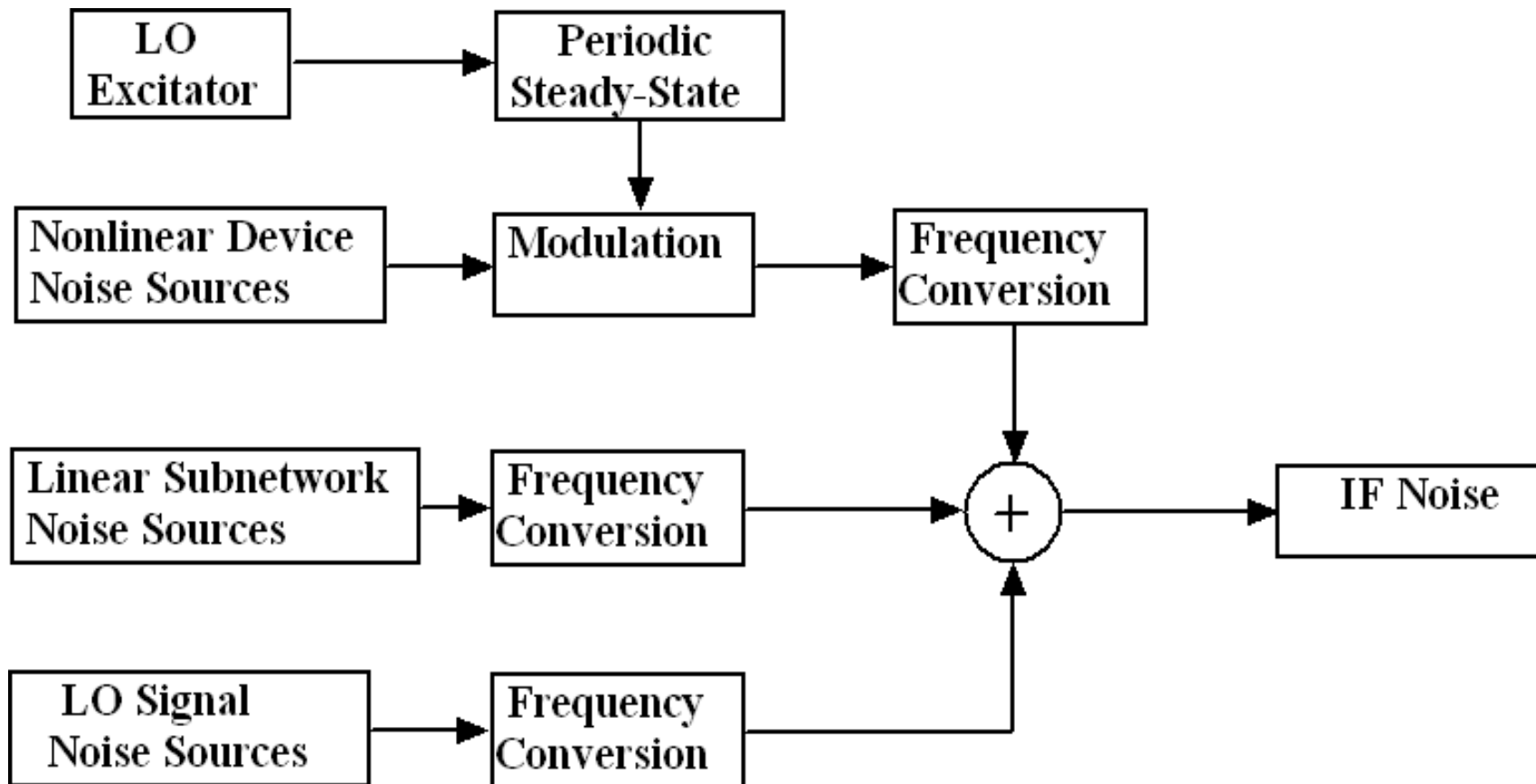

➤ SYNTHESIZED INDUCTOR , cont'd.

This Figure shows the typical plot of reactance and equivalent loss resistance of the synthesized inductor using high cut-off frequency ($f_t=75$ GHz) SiGe HBTs.

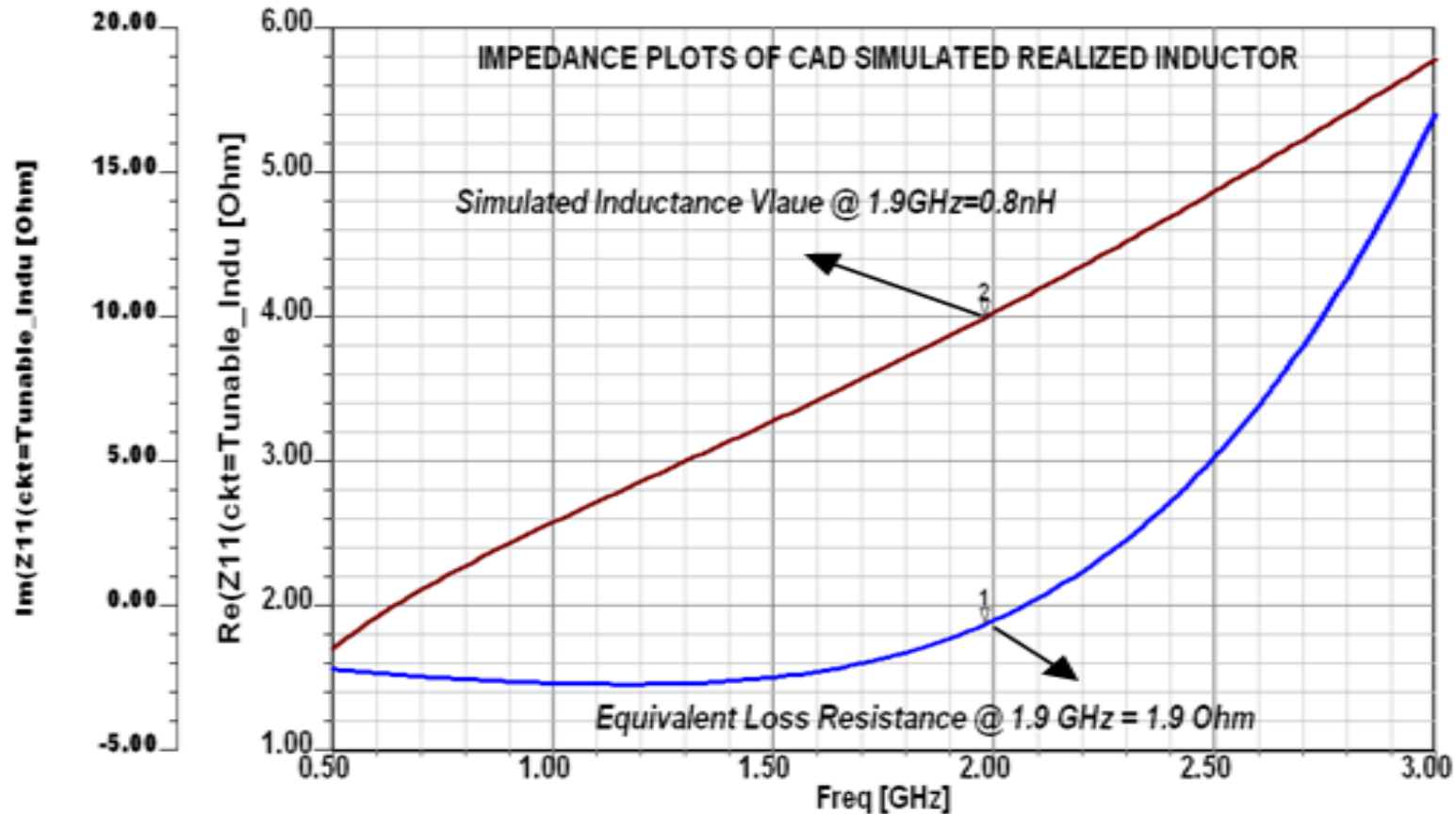

As shown in Figure, the value of the realized inductance and associated equivalent loss resistance are 0.8nH and 1.9 Ω at 1.9 GHz for the operating DC bias condition (3V, 1.8mA) and V_{tune} (2.5V). The operating DC bias and V_{tune} are adjusted in such a way that realized equivalent noise resistance must be positive to avoid the multi-mode oscillations caused by the regenerative effect (if the simulated loss resistance associated with realized inductor is negative in value).

➤ SYNTHESIZED INDUCTOR-TUNED OSCILLATOR

Realized Inductor-Tuned Oscillator

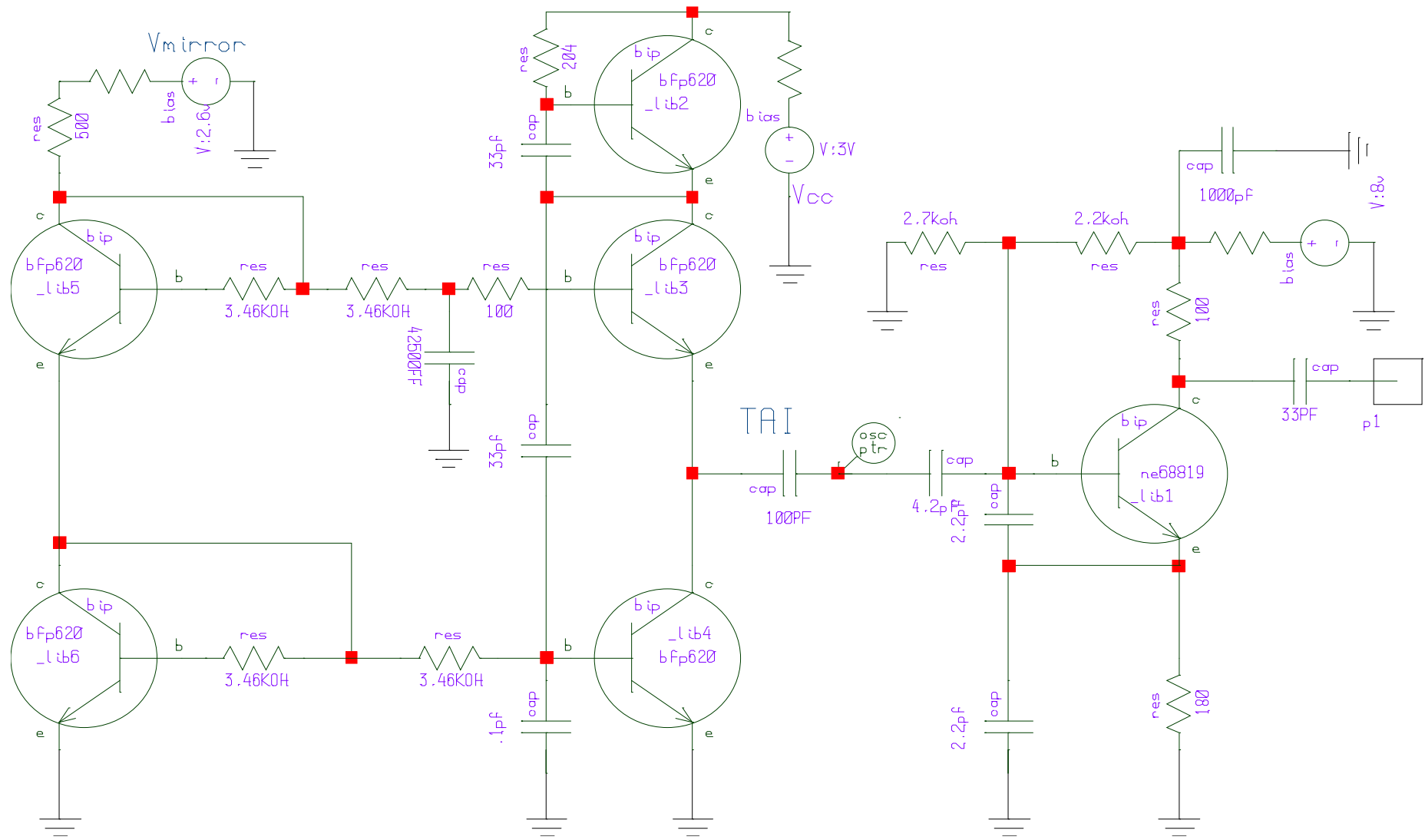

Schematic of the Colpitts oscillator circuits using CAD simulated inductor (0.8 nH, 1.9 Ω)

OUTLINE

- **Introduction**
- **What is an oscillator?**
- **Introduction to Microwave Oscillators and Their Mathematical Treatment**
- **Transistor Types**
- **Transistor models and Noise Contributions**
- **Linear Approach to the Calculation of Oscillator Phase Noise**
- **Typical Microwave Oscillator (Colpitts Oscillator)**
- **Designing an Oscillator**
- **Tuning Diode Noise Contribution**
- **Designing an Oscillator based on Linear S-Parameters**
- **Large signal Operation of Oscillators (Colpitts/YIG)**
- **Classical Linear Two-Port Oscillator Design**
- **Microwave Resonators**
- **A Novel Tunable Active Spiral Inductor**
- **The Active Inductor Using a Gyrator**
- **INTRODUCTION: Active Inductor Oscillator**
- **Synthesized Inductor Circuits**
- **Phase Noise Contribution of the Various Parts of the Oscillator Using an Active Inductor**
- **The Modern Time-Domain Behavior of an Oscillator**
- **Test Case: Design Example of a 100MHz crystal oscillator**
- **Phase Noise Analysis Based on the Negative Resistance Model**
- **Oscillator Phase Noise**
- **Design Examples of Oscillators for Best Phase Noise and Good Output Power**
- **Phase Noise of the integrated CMOS oscillator**
- **Appendix: A Solution for Calculating Phase Noise in Oscillators**
 - **Oscillator Noise Models**
 - **Noise Generation in Oscillators**
- **Key References**

➤ SIMULATED OSCILLATOR PHASE NOISE PLOTS

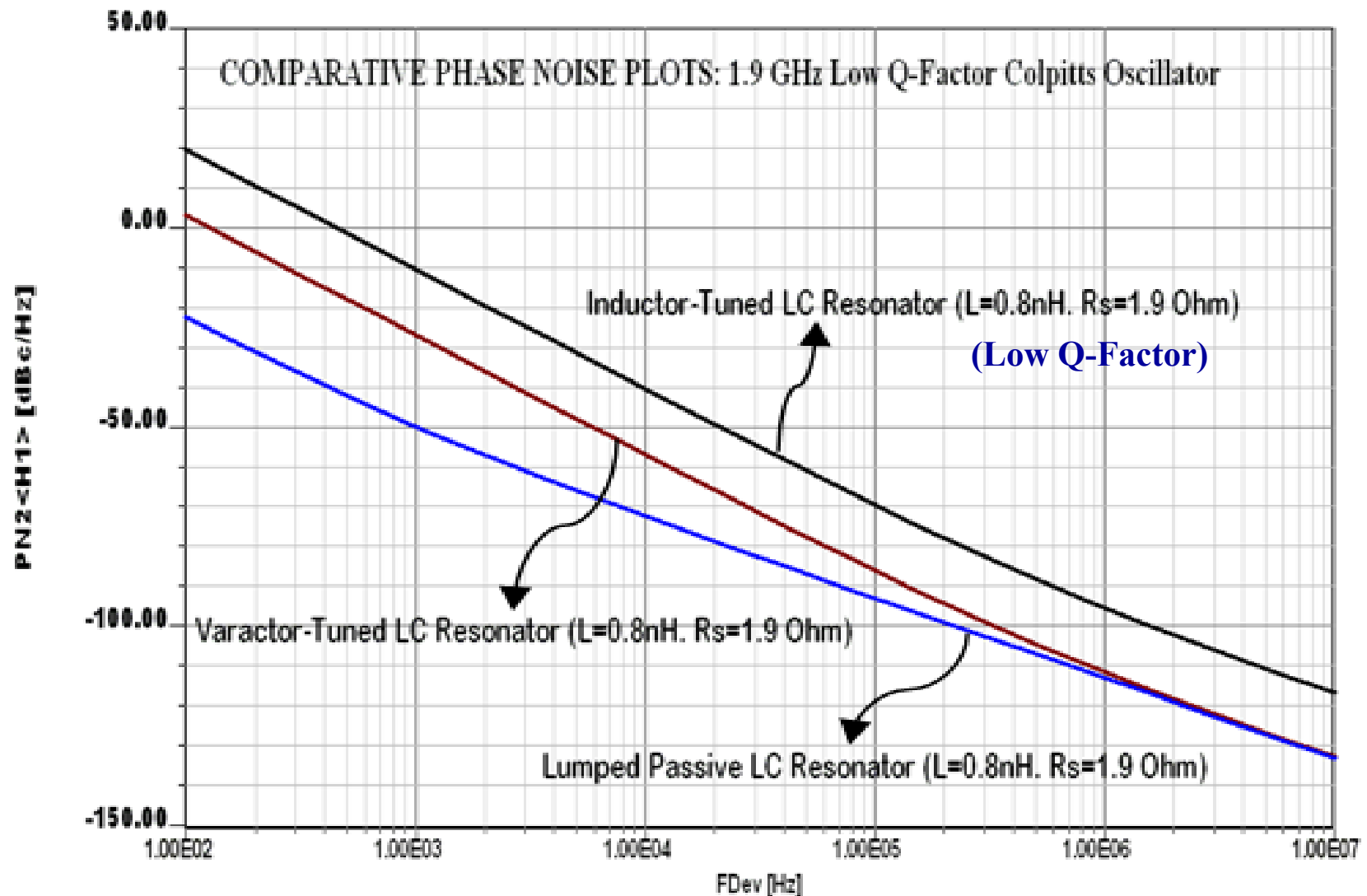

This plot shows the comparative phase noise plots for the LC Colpitts oscillator using the lumped LC resonator, the varactor-tuned lumped LC resonator and the synthesized inductor-tuned resonator network for identical inductance value and loss resistance (0.8 nH with series loss resistance 1.9 Ω).

➤ ACTIVE INDUCTOR NOISE

Capacitor loaded gyrator based active inductor resonator with noise source

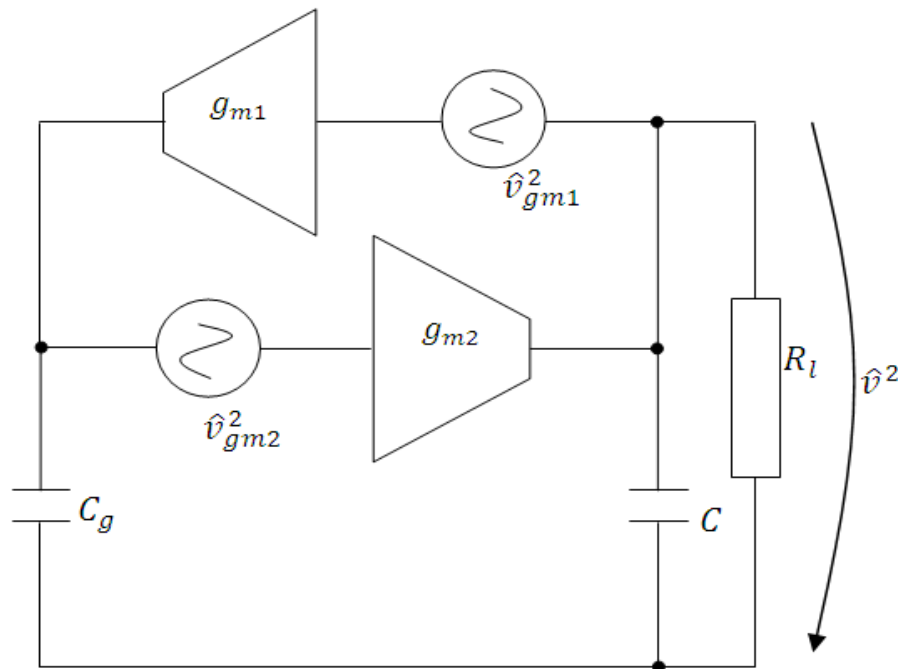

A simplified circuit of active inductor resonator with noise sources

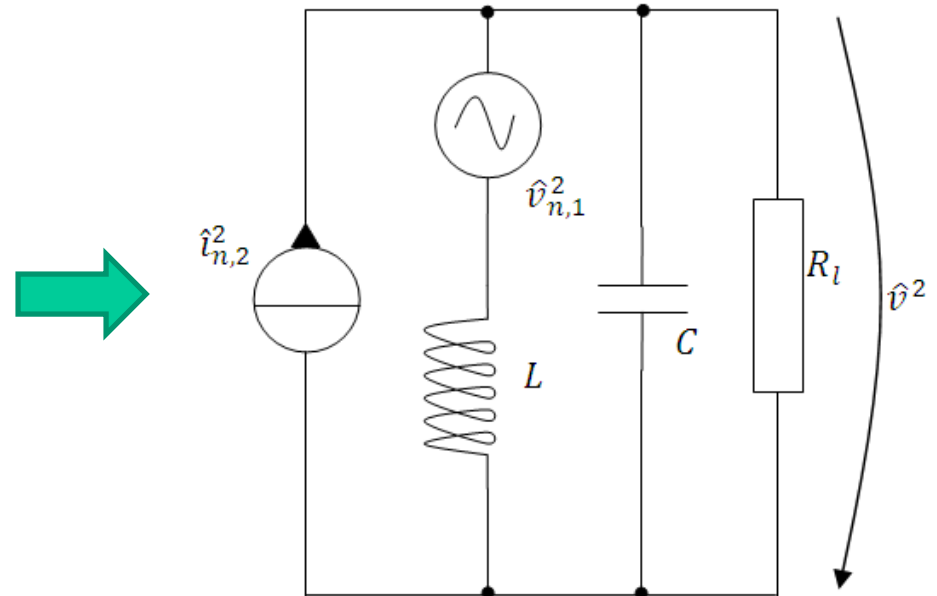

$$\hat{v}_{n,1}^2 = \hat{v}_{gm1}^2 \cong \frac{4kT\lambda}{g_m}$$

$$\hat{i}_{n,2}^2 = \hat{g}_{gm2}^2 \hat{v}_{gm2}^2 = 4kT\lambda g_m$$

V_{gm1} and V_{gm2} are the equivalent noises from the transconductances of the Gytrators

➤ ACTIVE INDUCTOR NOISE, cont'd.

Since

$$\hat{v}_n^2 \cong 4kTr_n|R|, \quad \hat{i}_n^2 \cong 4kTg_n|G|$$

where R and G are the negative resistance and conductance values, and the coefficients r_n and g_n are frequency dependent relative noise resistance and conductance (these give a comparative value of how much noise the active negative resistor produces compared to a passive resistor of the same value).

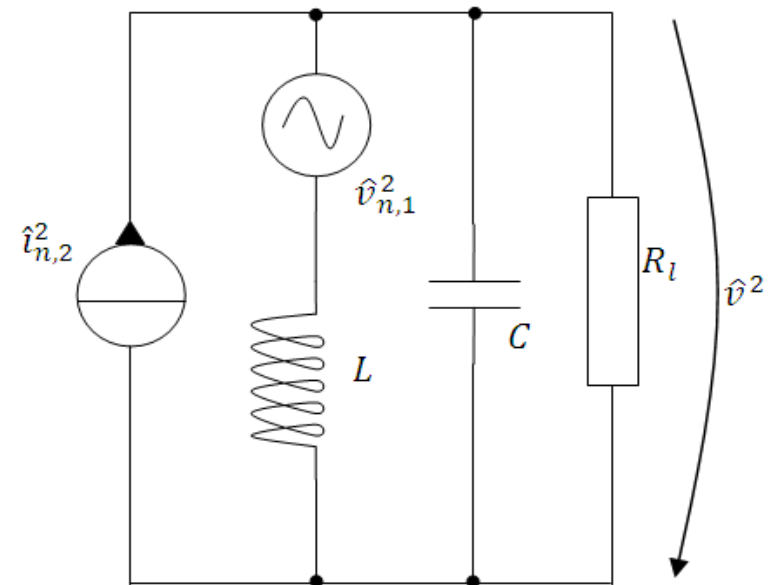

The total noise voltage spectral density of the active inductor resonator is

$$\hat{v}^2 = \frac{\hat{v}_{g_{m1}}^2 + \hat{v}_{g_{m2}}^2 g_{m2}^2 \omega^2 L^2}{\omega^2 L^2 G_l^2 + (\omega^2 LC - 1)^2} \Rightarrow \hat{v}^2|_{\omega \rightarrow \omega_0} = Q_l^2 (\hat{v}_{g_{m1}}^2 + g_{m2}^2 \hat{v}_{g_{m2}}^2 \omega^2 L^2) = 4kT\lambda Q_l^2 \left(\frac{1}{g_{m1}} + \frac{g_{m2}}{\omega_0^2 C^2} \right)$$

The time average Q-factor of active inductor is

$$\frac{\omega_0(1+r_n, g_n)}{\lambda g_{m2} \left(\frac{1}{C} + \frac{1}{C_g} \right)}$$

➤ ACTIVE INDUCTOR NOISE, cont'd.

The time average normalized noise power of an active inductor resonator can be determined by

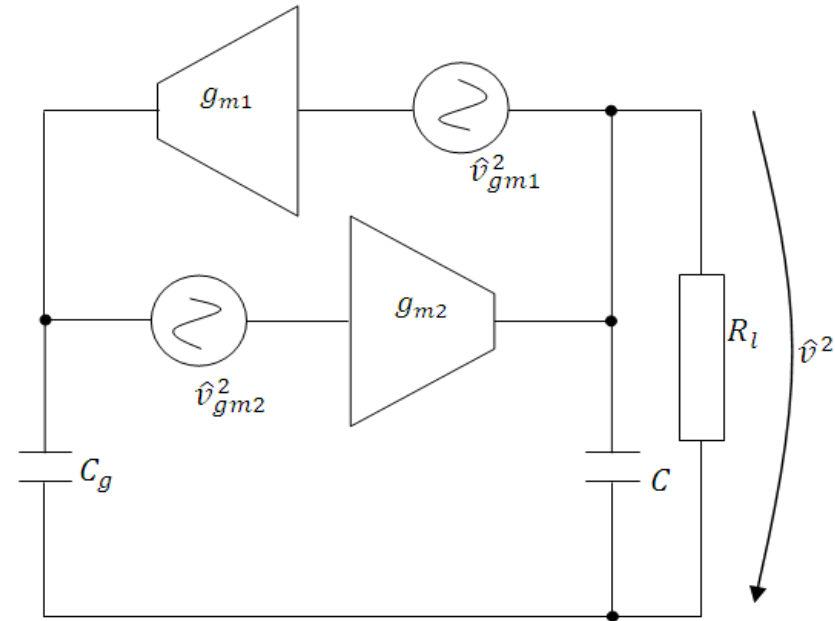

$$\overline{v^2} = \int_0^{\infty} \hat{v}^2 df = \frac{\hat{v}_{gm1}^2}{2\pi} \omega_o \int_0^{\infty} \frac{d\omega}{[(\omega^2 LC - 1)^2 + \omega^2 L^2 G_l^2]} + \frac{\hat{g}_{gm2}^2 \hat{v}_{gm2}^2}{2\pi} \int_0^{\infty} \frac{\omega^2 L^2 d\omega}{[(\omega^2 LC - 1)^2 + \omega^2 L^2 G_l^2]}$$

$$\overline{v^2} \approx \frac{kT \lambda}{C} Q_l \left(\frac{g_{m2}}{g_{m1}} \right)^{1/2} \left[\left(\frac{C_g}{C} \right)^{1/2} + \left(\frac{C}{C_g} \right)^{1/2} \right] = \frac{kT \lambda}{C} Q_l \frac{\omega_o}{g_{m1}} (C + C_g)$$

➤ ACTIVE INDUCTOR OSCILLATOR PHASE NOISE

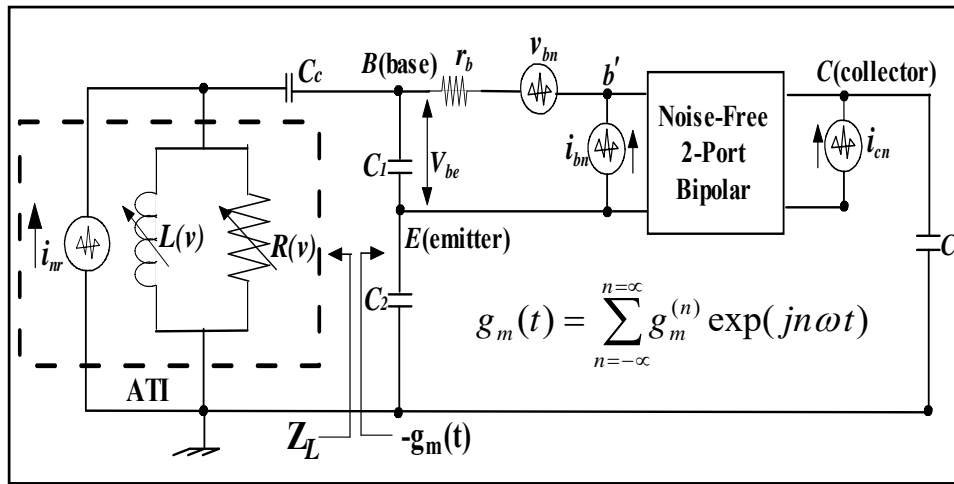

The total noise voltage power within 1 Hz bandwidth can be described by

$$\left| e_n^2(\omega) \right|_{\omega=\omega_0} = \overline{[e_n^2(\omega_0)]_{-gm1}} + \overline{[e_n^2(\omega_0)]_{-gm2}}$$

The first term is related to the active inductor noise due to the active inductor and the second term is related to negative resistance generative active device.

After some lengthy calculations and approximations, adding shot noise, flicker noise and the loss resistor, the equivalent expression of the phase noise is given by

$$\left| e_{g_{m2}}^2(\omega) \right|_{\omega=\omega_0} = [4kTR] + \left[\frac{4qI_{c0}g_{m2}^2 + \frac{4K_f I_b^{AF}}{\omega} g_{m2}^2}{\omega_0^2 C_1^2 [\omega_0^2 (\beta^+)^2 C_2^2 + g_{m2}^2 \frac{C_2^2}{C_1^2}]} \right]$$

$$g_{m2} = [Y_{21}^+] \left[\frac{C_1}{C_2} \right]^q$$

$$\beta^+ = \left[\frac{Y_{21}^+}{Y_{11}^+} \right] \left[\frac{C_1}{C_2} \right]^p$$

$$g_m(t) = \sum_{n=-\infty}^{n=\infty} g_m^{(n)} \exp(jn\omega t)$$

The values of p and q depend upon the drive level.

➤ ACTIVE INDUCTOR OSCILLATOR PHASE NOISE

After lengthy calculations and approximations, adding shot noise, flicker noise and the loss resistor, the equivalent expression of the phase noise is given by

$$L(\omega) = 10 \times \log \left[\left[k_0 + \frac{k^3 k_1 \left[\frac{Y_{21}^+}{Y_{11}^+} \right]^2 [y]^{2p}}{\left[Y_{21}^+ \right]^3 [y]^{3q}} \right] \left(\frac{1}{(y^2 + k)} \right) \left[\frac{[1 + y]^2}{y^2} \right] \right]$$

$$k_0 = \frac{kTR}{\omega^2 \omega_0^2 C_2^2 L_{active-inductor}^2 V_{cc}^2} \quad k_1 = \frac{qI_c g_{m2}^2 + \frac{K_f I_b^{AF}}{4\omega} g_{m2}^2}{\omega^2 \omega_0^4 L_{active-inductor}^2 V_{cc}^2} \quad k_2 = \omega_0^4 (\beta^+)^2 \quad k_3 = \omega_0^2 g_{m2}^2$$

$$k = \frac{k_3}{k_2 C_2^2} \quad L_{active-inductor} = \frac{C_1 C_2}{[C_1 + C_2] g_{m1}^2} \quad g_m(t) = \sum_{n=-\infty}^{n=\infty} g_m^{(n)} \exp(jn\omega t)$$

$$g_{m2} = \left[Y_{21}^+ \right] \left[\frac{C_1}{C_2} \right]^q \quad \beta^+ = \left[\frac{Y_{21}^+}{Y_{11}^+} \right] \left[\frac{C_1}{C_2} \right]^p \quad y = \frac{C_1}{C_2}$$

The values of p and q depend upon the drive level.

➤ TAI OSCILLATOR VALIDATION EXAMPLE

Self-Injection-Locked 1.9 GHz Tunable Inductor Oscillator

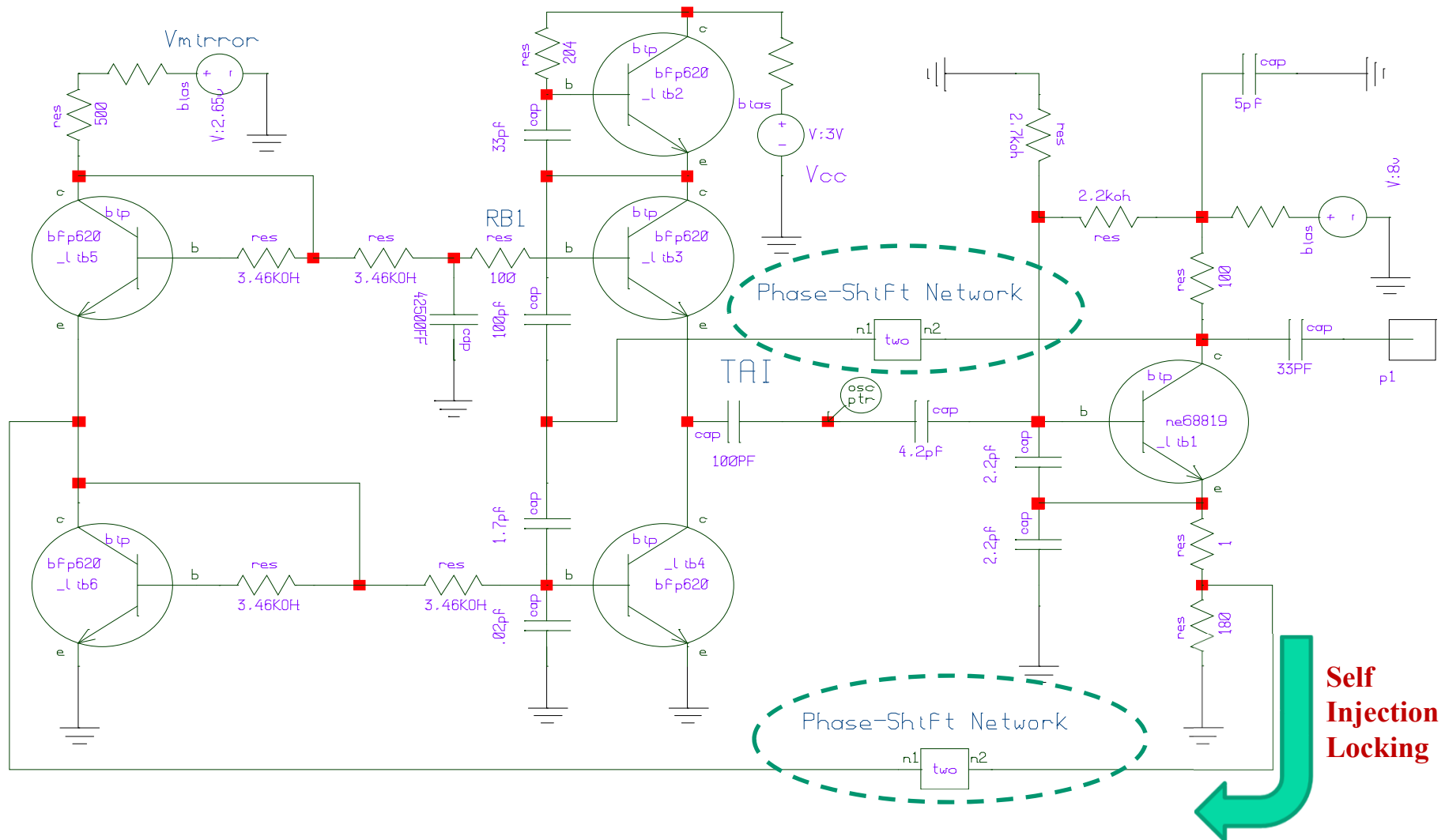

This Figure shows the schematic of self-injection-locked inductor-tuned Colpitts oscillator realized by incorporating phase shifter network in the feedback path, which improves the $1/f$ noise, including linearization of the large signal drive-level characteristics of the synthesized inductor circuits.

➤ ACTIVE INDUCTOR OSCILLATOR PHASE NOISE PLOTS

CAD simulated phase noise plot

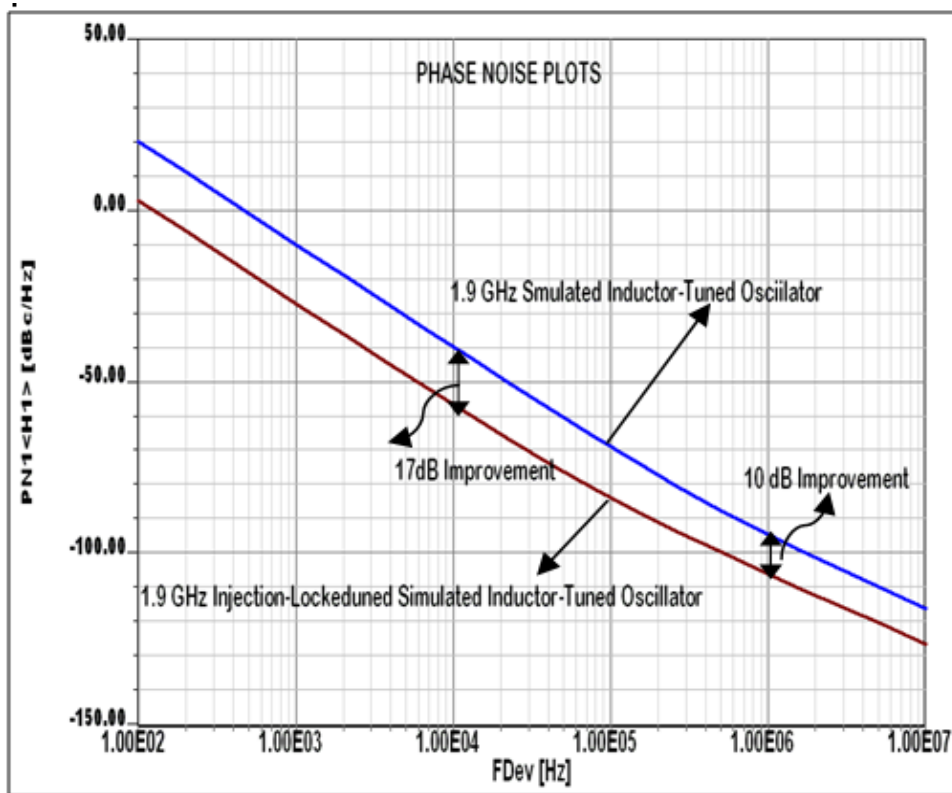

Measured phase noise plot (Injection-Locked)

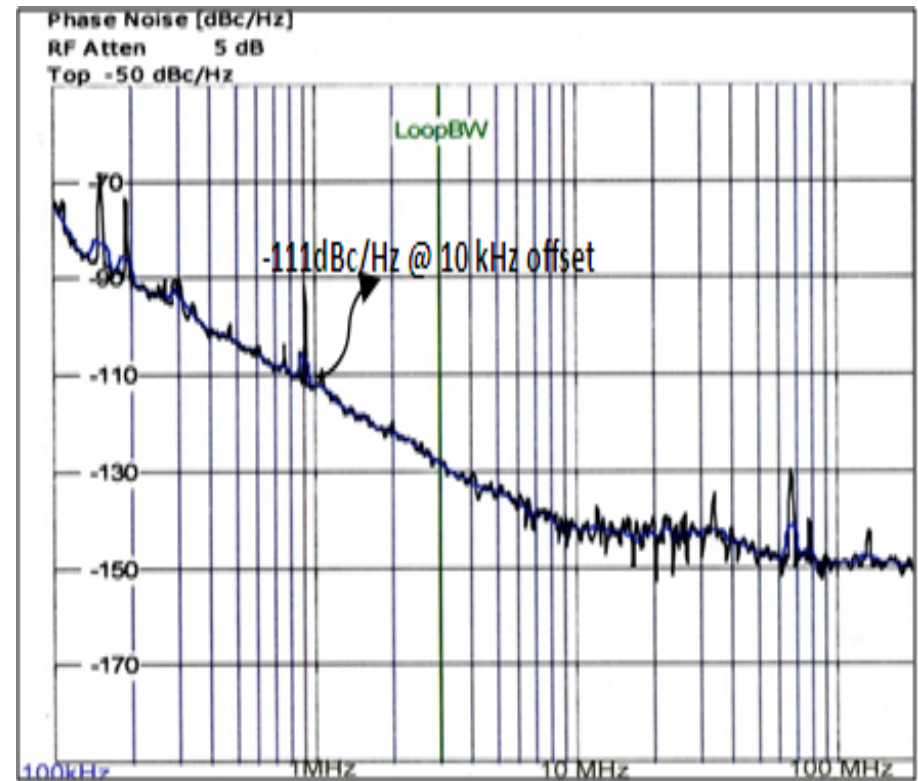

Figures show the CAD simulated (WITH AND WITHOUT INJECTION LOCKING) and measured phase noise plot of injection locked 1.9 GHz TAI. As shown in Figure, injection-locking improves the phase noise performance by 8-10 dB, including the locking range.

TUNABLE ACTIVE INDUCTOR - RECAP

- ✓ **This research work demonstrates the state-of-the-art in designing tunable inductor based VCO (voltage controlled oscillator) circuits**
- ✓ **Use of TAI (Tunable Active Inductor) resonator is relatively new and its application to replace tuning diodes in VCO (voltage controlled oscillator) have recently begun to be explored**
- ✓ **Closed form noise models for TAI VCOs involved complex mathematical treatment due to the convergence problems at large drive-level**
- ✓ **Limitation in the dynamic range may restricts the applications in high performance tunable filters, nevertheless by incorporating my novel techniques one can improve the dynamic range up to an accepted limit**

TAI - RECAP

- ✓ **The behavior of the TAI (Tunable Active Inductor) oscillator was studied and verified with practical examples.**
- ✓ **Intensive studies were conducted to find the optimum configuration for the improvement in the phase noise over the tuning range, and a US Patent application was filed.**
- ✓ **The extension of the research work is to increase the tuning range and dynamic range by employing injection mode coupling and noise cancellation techniques in monolithic IC technology.**
- ✓ **I expect to see continued research in this field and the use of TAI (Tunable Active Inductor) components as a cost-effective alternative of tuning diodes (Varactor) as a tuning element in filter, resonator, antenna matching network and phase shifter for the applications in concurrent and configurable RF & MW modules/systems.**

OUTLINE

- **Introduction**
- **What is an oscillator?**
- **Introduction to Microwave Oscillators and Their Mathematical Treatment**
- **Transistor Types**
- **Transistor models and Noise Contributions**
- **Linear Approach to the Calculation of Oscillator Phase Noise**
- **Typical Microwave Oscillator (Colpitts Oscillator)**
- **Designing an Oscillator**
- **Tuning Diode Noise Contribution**
- **Designing an Oscillator based on Linear S-Parameters**
- **Large signal Operation of Oscillators (Colpitts/YIG)**
- **Classical Linear Two-Port Oscillator Design**
- **Microwave Resonators**
- **A Novel Tunable Active Spiral Inductor**
- **The Active Inductor Using a Gyrator**
- **INTRODUCTION: Active Inductor Oscillator**
- **Synthesized Inductor Circuits**
- **Phase Noise Contribution of the Various Parts of the Oscillator Using an Active Inductor**
- **The Modern Time-Domain Behavior of an Oscillator**
- **Test Case: Design Example of a 100MHz crystal oscillator**
- **Phase Noise Analysis Based on the Negative Resistance Model**
- **Oscillator Phase Noise**
- **Design Examples of Oscillators for Best Phase Noise and Good Output Power**
- **Phase Noise of the integrated CMOS oscillator**
- **Appendix: A Solution for Calculating Phase Noise in Oscillators**
 - **Oscillator Noise Models**
 - **Noise Generation in Oscillators**
- **Key References**

➤ THE MODERN TIME-DOMAIN BEHAVIOR OF AN OSCILLATOR

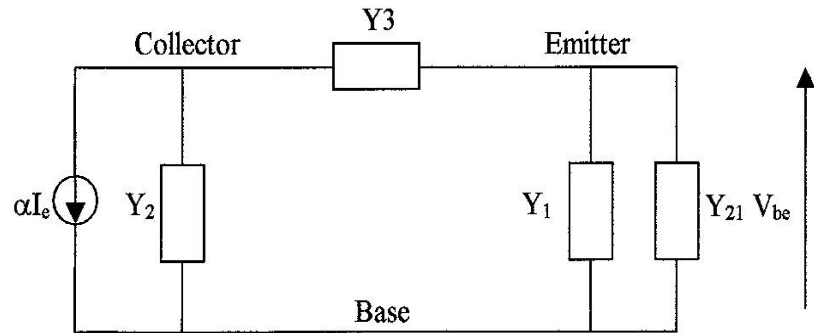

Equivalent oscillator circuit for the analysis of the transformed conductance seen by the current source

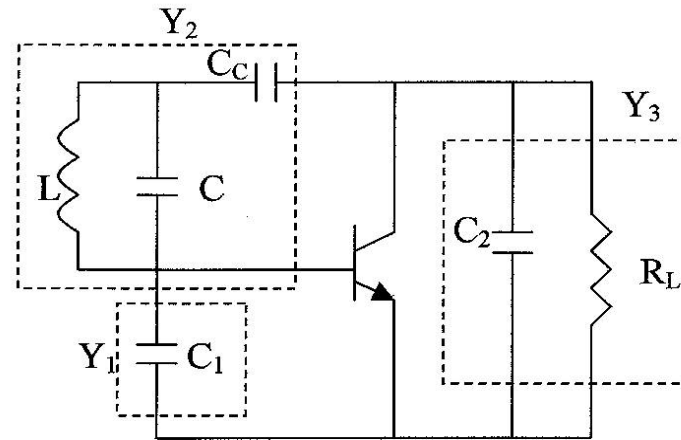

Oscillator circuit with the passive components Y_1 , Y_2 and Y_3

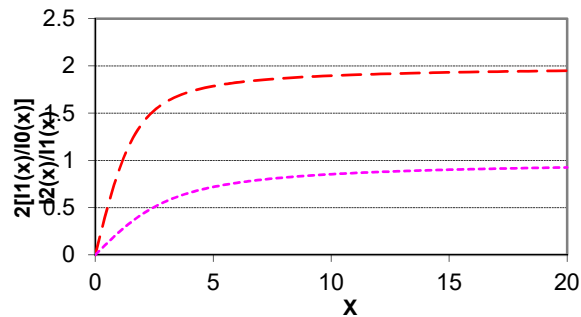

Plot of the normalized fundamental current $2I_1(x)/I_0(x)$ and second harmonic $I_2(x)/I_1(x)$ with respect to the drive level x

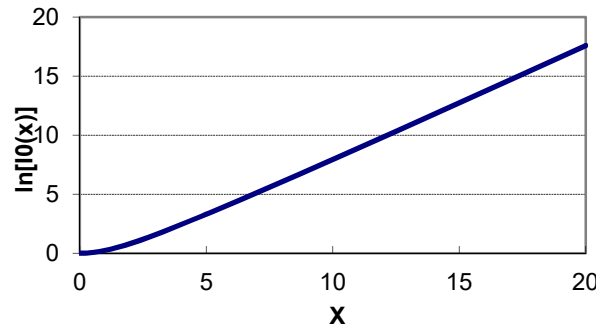

Plot of $[\ln I_0(x)]$ Vs drive level X

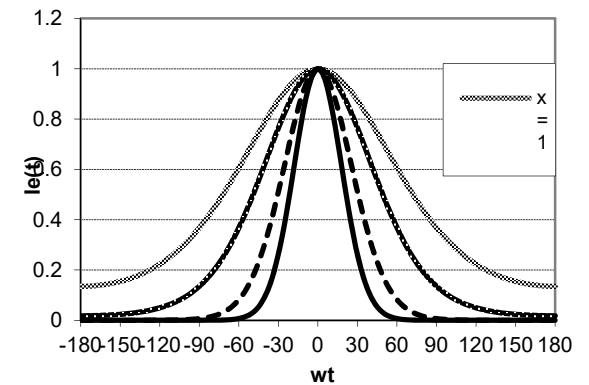

Plot of current with respect to conduction angle- (wt) and drive level X

OUTLINE

- **Introduction**
- **What is an oscillator?**
- **Introduction to Microwave Oscillators and Their Mathematical Treatment**
- **Transistor Types**
- **Transistor models and Noise Contributions**
- **Linear Approach to the Calculation of Oscillator Phase Noise**
- **Typical Microwave Oscillator (Colpitts Oscillator)**
- **Designing an Oscillator**
- **Tuning Diode Noise Contribution**
- **Designing an Oscillator based on Linear S-Parameters**
- **Large signal Operation of Oscillators (Colpitts/YIG)**
- **Classical Linear Two-Port Oscillator Design**
- **Microwave Resonators**
- **A Novel Tunable Active Spiral Inductor**
- **The Active Inductor Using a Gyrator**
- **INTRODUCTION: Active Inductor Oscillator**
- **Synthesized Inductor Circuits**
- **Phase Noise Contribution of the Various Parts of the Oscillator Using an Active Inductor**
- **The Modern Time-Domain Behavior of an Oscillator**
- **Test Case: Design Example of a 100MHz crystal oscillator**
- **Phase Noise Analysis Based on the Negative Resistance Model**
- **Oscillator Phase Noise**
- **Design Examples of Oscillators for Best Phase Noise and Good Output Power**
- **Phase Noise of the integrated CMOS oscillator**
- **Appendix: A Solution for Calculating Phase Noise in Oscillators**
 - **Oscillator Noise Models**
 - **Noise Generation in Oscillators**
- **Key References**

TEST CASE: DESIGN EXAMPLE OF A 100MHz CRYSTAL OSCILLATOR

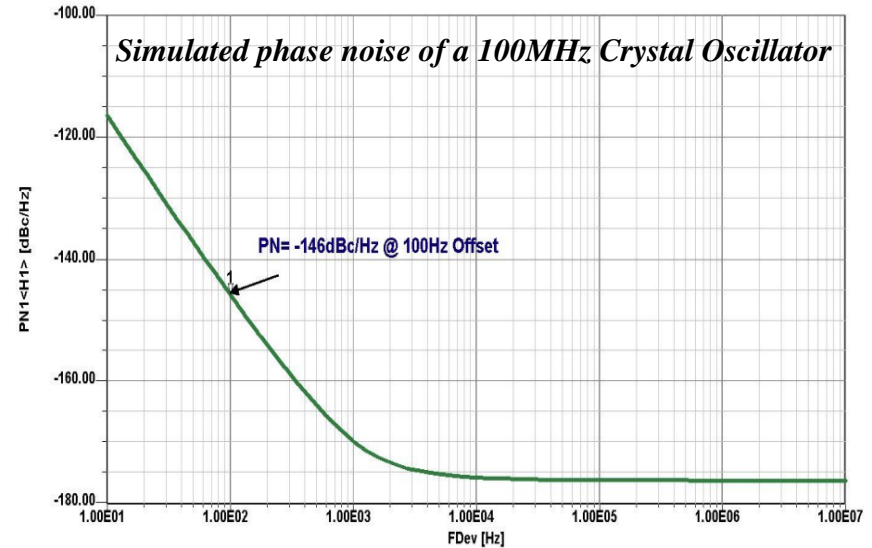
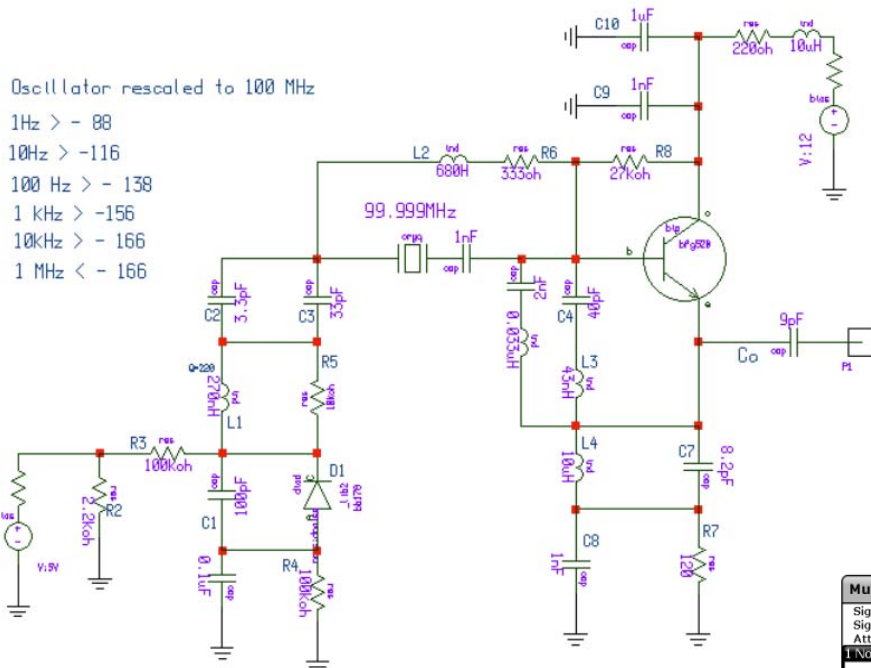

Crystal Oscillator simulated schematic scaled to 100 MHz based on the 10MHz HP10811A Circuit

Calculated phase noise for a 100MHz Crystal Oscillator

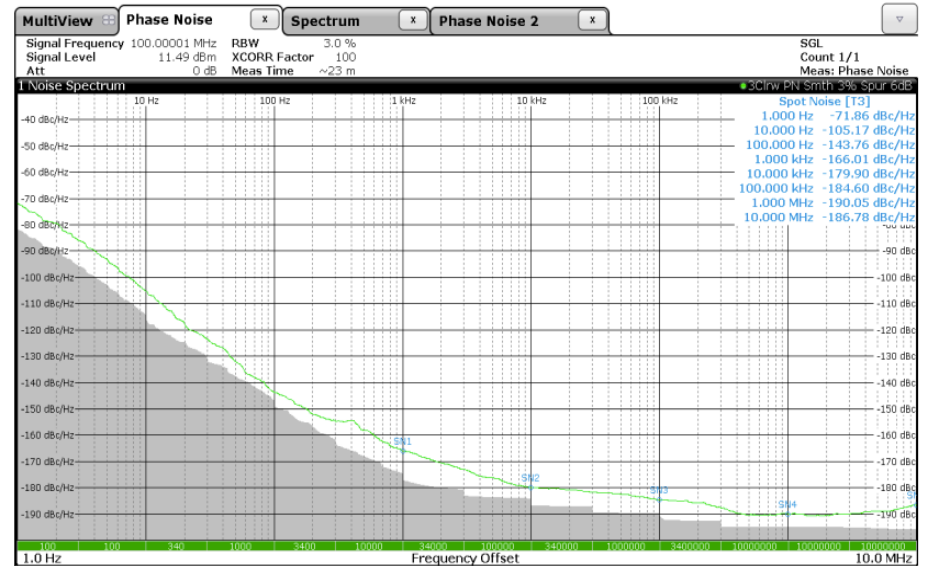
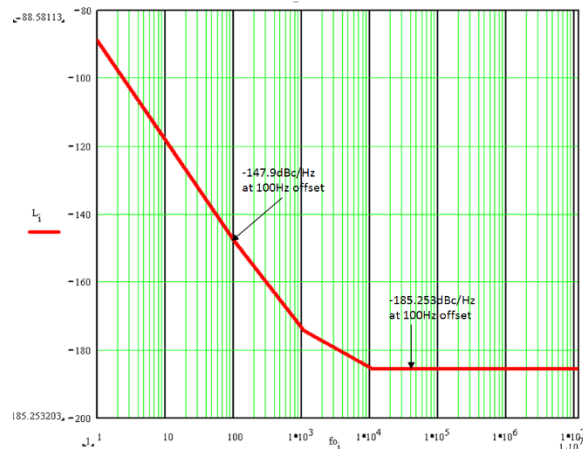

Measured phase noise of a 100MHz Crystal Oscillator

OUTLINE

- **Introduction**
- **What is an oscillator?**
- **Introduction to Microwave Oscillators and Their Mathematical Treatment**
- **Transistor Types**
- **Transistor models and Noise Contributions**
- **Linear Approach to the Calculation of Oscillator Phase Noise**
- **Typical Microwave Oscillator (Colpitts Oscillator)**
- **Designing an Oscillator**
- **Tuning Diode Noise Contribution**
- **Designing an Oscillator based on Linear S-Parameters**
- **Large signal Operation of Oscillators (Colpitts/YIG)**
- **Classical Linear Two-Port Oscillator Design**
- **Microwave Resonators**
- **A Novel Tunable Active Spiral Inductor**
- **The Active Inductor Using a Gyrator**
- **INTRODUCTION: Active Inductor Oscillator**
- **Synthesized Inductor Circuits**
- **Phase Noise Contribution of the Various Parts of the Oscillator Using an Active Inductor**
- **The Modern Time-Domain Behavior of an Oscillator**
- **Test Case: Design Example of a 100MHz crystal oscillator**
- **Phase Noise Analysis Based on the Negative Resistance Model**
- **Oscillator Phase Noise**
- **Design Examples of Oscillators for Best Phase Noise and Good Output Power**
- **Phase Noise of the integrated CMOS oscillator**
- **Appendix: A Solution for Calculating Phase Noise in Oscillators**
 - **Oscillator Noise Models**
 - **Noise Generation in Oscillators**
- **Key References**

➤ OSCILLATOR PHASE NOISE

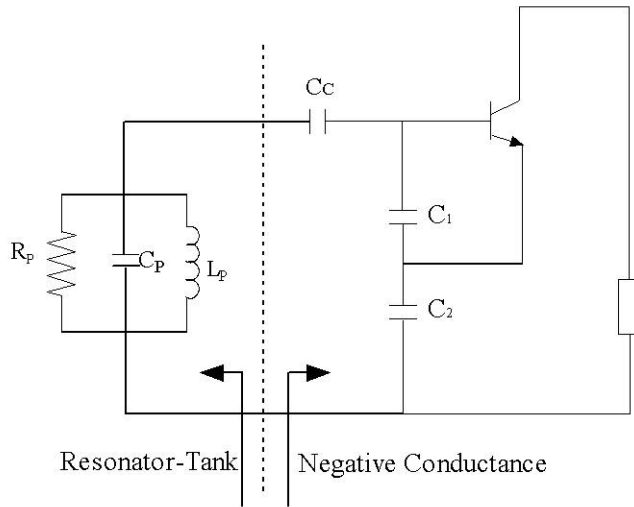

Colpitts Oscillator configuration for the intrinsic case, no parasitics assumed, and an ideal transistor considered

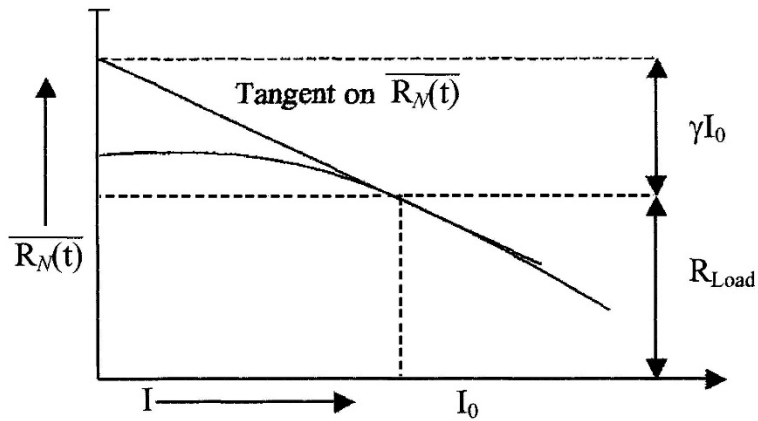

Plot of negative resistance

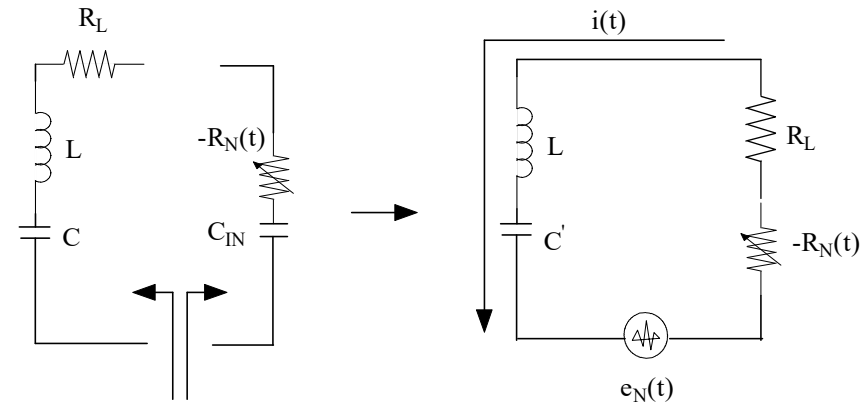

Equivalent representation of the oscillator circuit in presence of noise

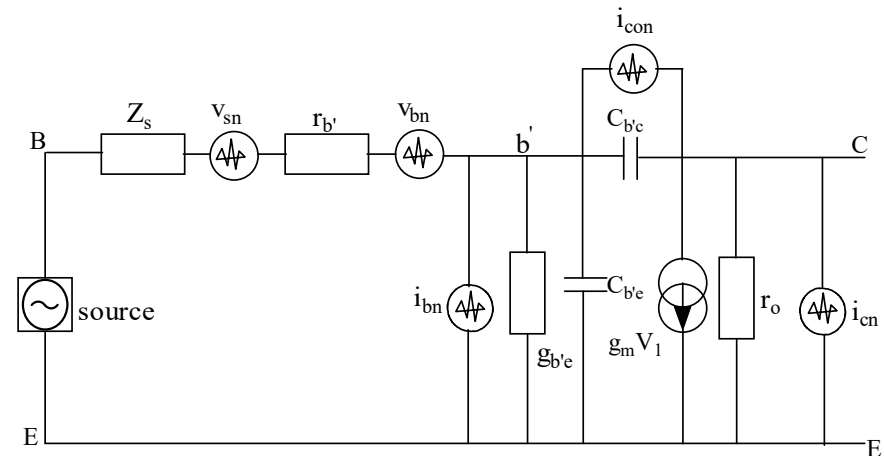

Hybrid- π configuration of the grounded bipolar transistor with noise sources

OUTLINE

- **Introduction**
- **What is an oscillator?**
- **Introduction to Microwave Oscillators and Their Mathematical Treatment**
- **Transistor Types**
- **Transistor models and Noise Contributions**
- **Linear Approach to the Calculation of Oscillator Phase Noise**
- **Typical Microwave Oscillator (Colpitts Oscillator)**
- **Designing an Oscillator**
- **Tuning Diode Noise Contribution**
- **Designing an Oscillator based on Linear S-Parameters**
- **Large signal Operation of Oscillators (Colpitts/YIG)**
- **Classical Linear Two-Port Oscillator Design**
- **Microwave Resonators**
- **A Novel Tunable Active Spiral Inductor**
- **The Active Inductor Using a Gyrator**
- **INTRODUCTION: Active Inductor Oscillator**
- **Synthesized Inductor Circuits**
- **Phase Noise Contribution of the Various Parts of the Oscillator Using an Active Inductor**
- **The Modern Time-Domain Behavior of an Oscillator**
- **Test Case: Design Example of a 100MHz crystal oscillator**
- **Phase Noise Analysis Based on the Negative Resistance Model**
- **Oscillator Phase Noise**
- **Design Examples of Oscillators for Best Phase Noise and Good Output Power**
- **Phase Noise of the integrated CMOS oscillator**
- **Appendix: A Solution for Calculating Phase Noise in Oscillators**
 - **Oscillator Noise Models**
 - **Noise Generation in Oscillators**
- **Key References**

➤ DESIGN EXAMPLES OF OSCILLATORS FOR BEST PHASE NOISE AND GOOD OUTPUT POWER

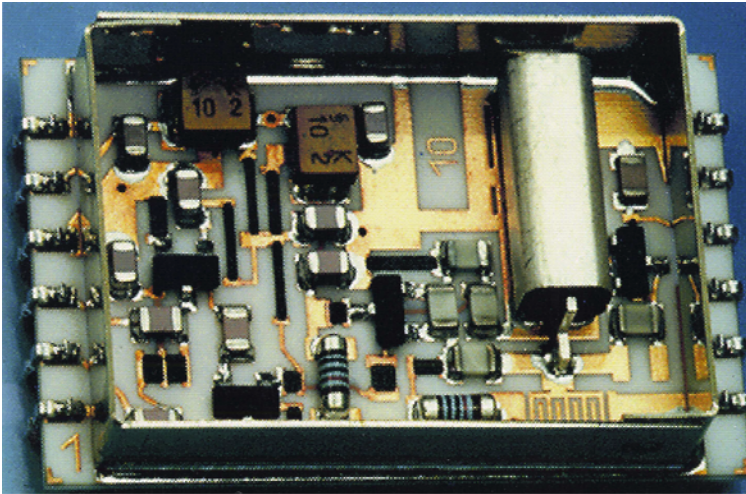

Parallel-tuned Colpitts oscillator using a ceramic resonator circuit, built and measured

100MHz_Parallel-Tuned_Resonator_Oscillator

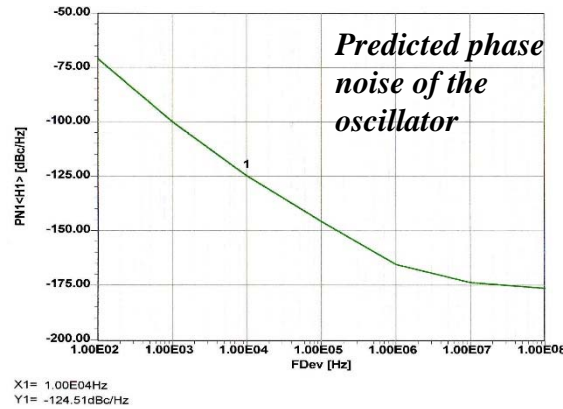
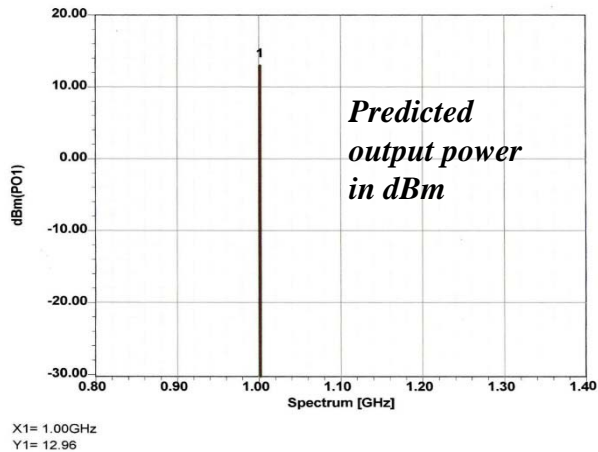
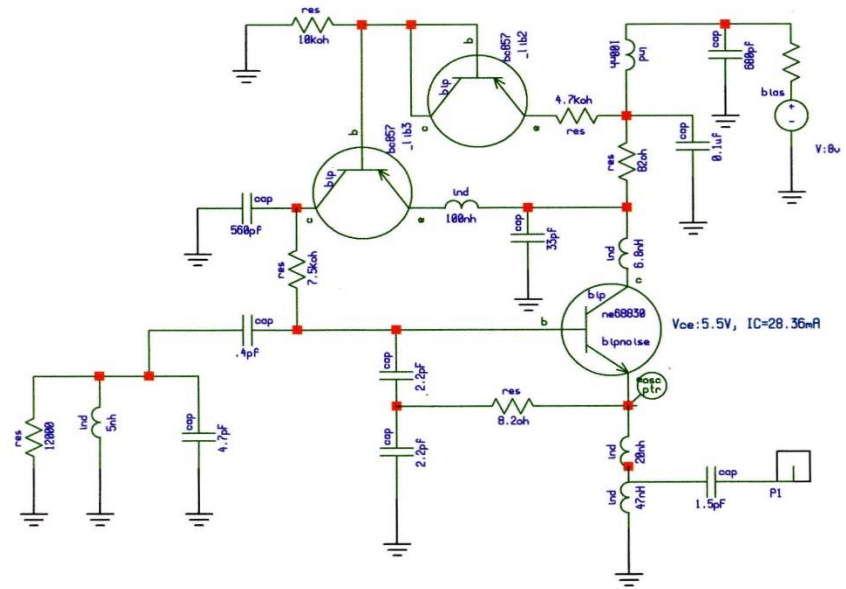

Current distribution in the oscillator circuit

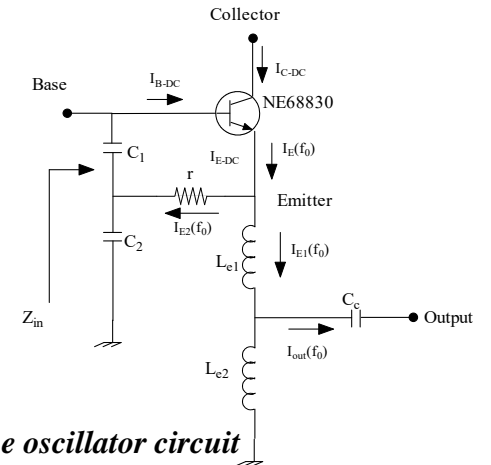

➤ DESIGN EXAMPLES OF OSCILLATORS FOR BEST PHASE NOISE AND GOOD OUTPUT POWER

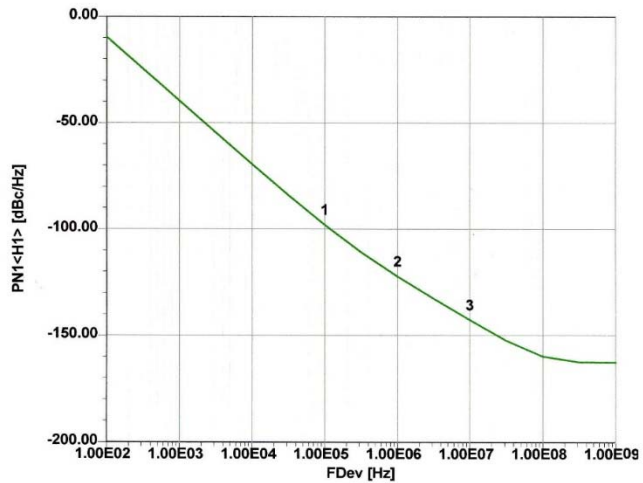

Predicted phase noise of the oscillator. The measured values were 100 dBc/Hz at 100 kHz and 120 dBc/Hz at 1 MHz. There is a deviation of about 2 dB compared to simulation

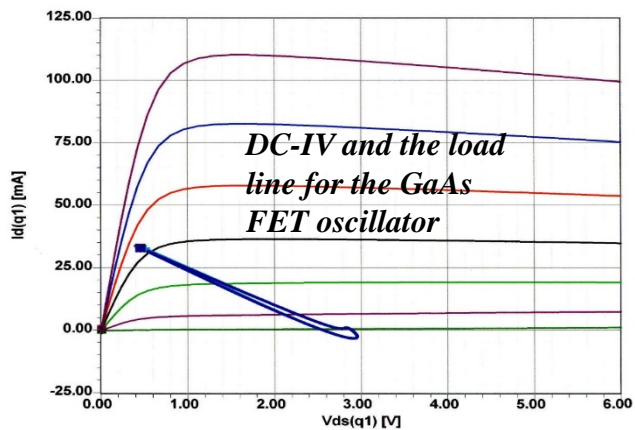

Circuit schematic the 2 GHz GaAs FET oscillator built on GaAs substrate with very fine resolution of the components

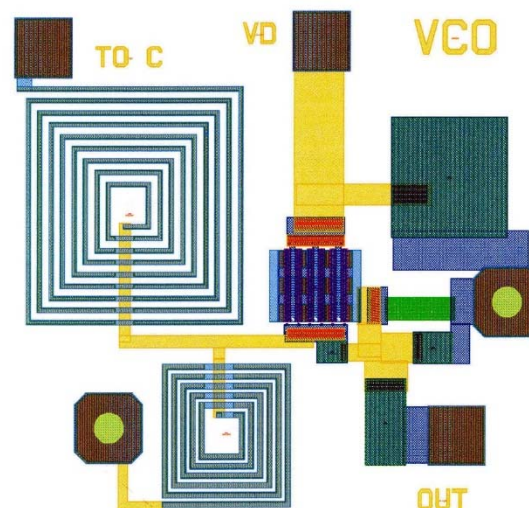
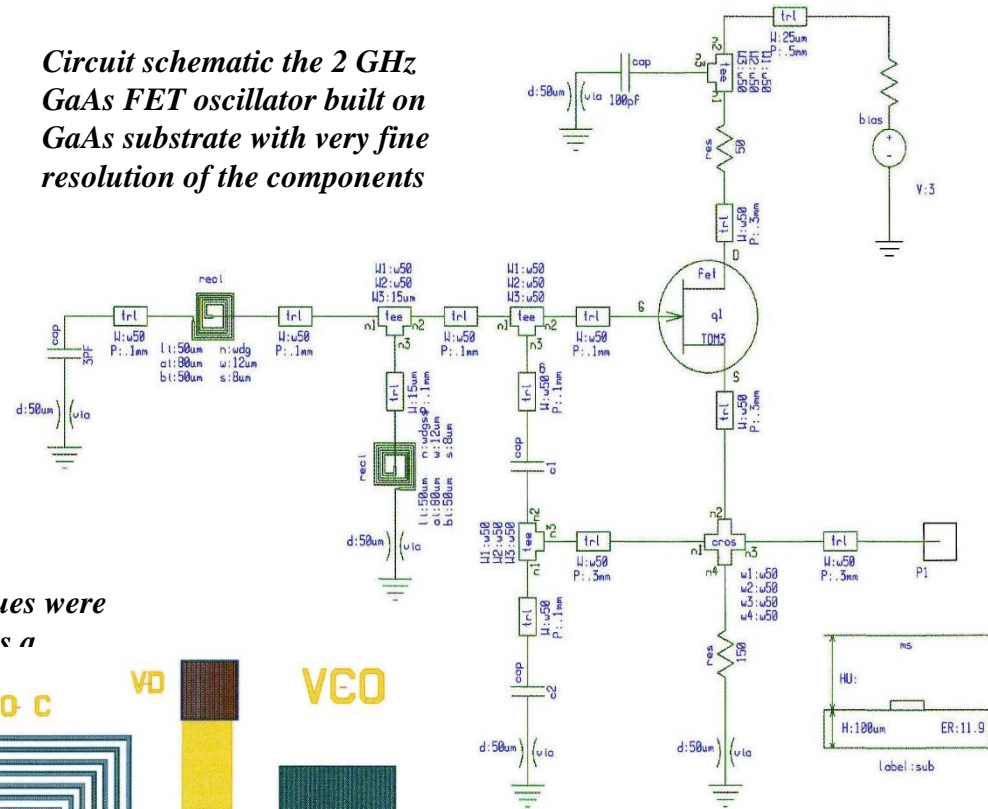

Layout of the 2 GHz GaAs FET oscillator

➤ DESIGN EXAMPLES OF OSCILLATORS FOR BEST PHASE NOISE AND GOOD OUTPUT POWER

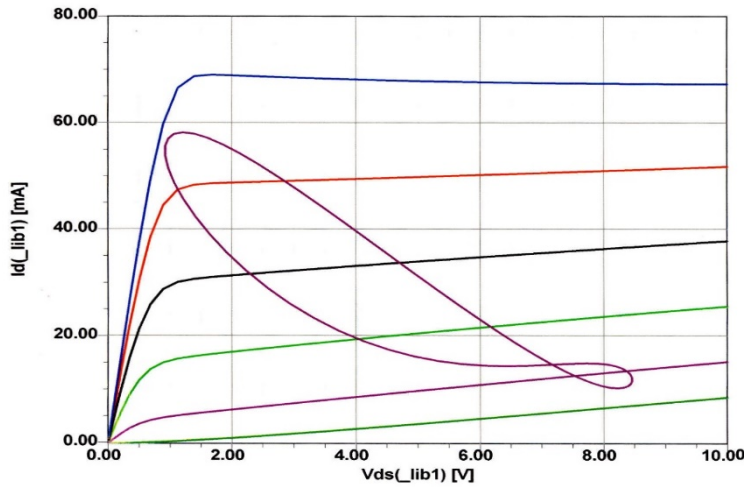

Load line of the MESFET oscillator - Because the load is a tuned circuit, the “load line” is a curve and not a straight line

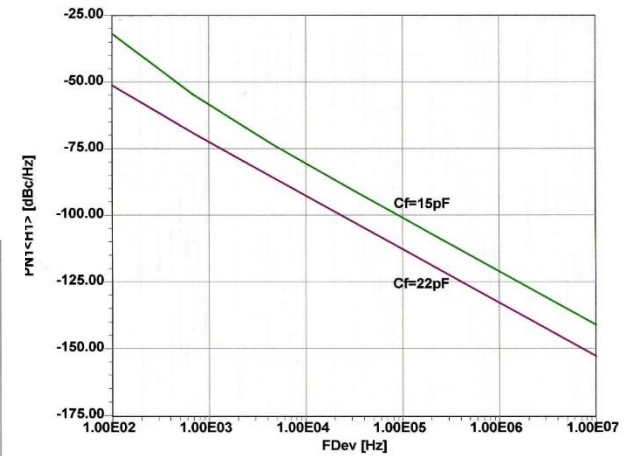
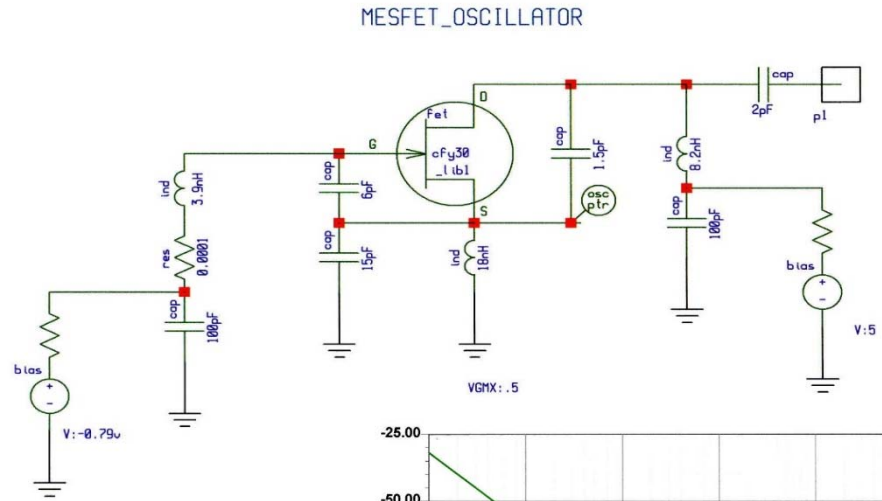

Simulated noise figure - An increase of the feedback capacitor from 15 to 22pF improves the phase noise

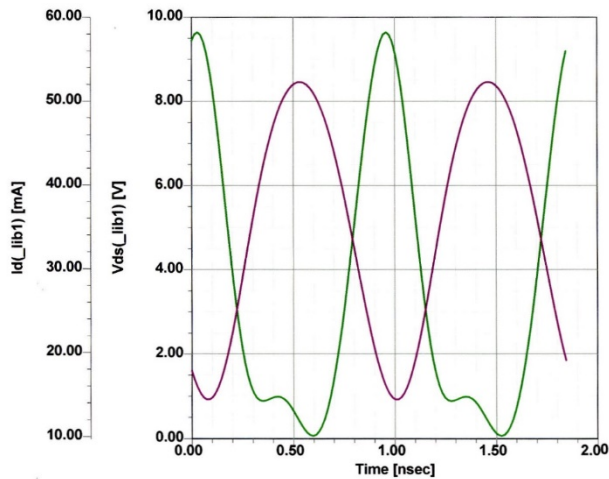

Plot of drain current and drain source voltage as a function of time

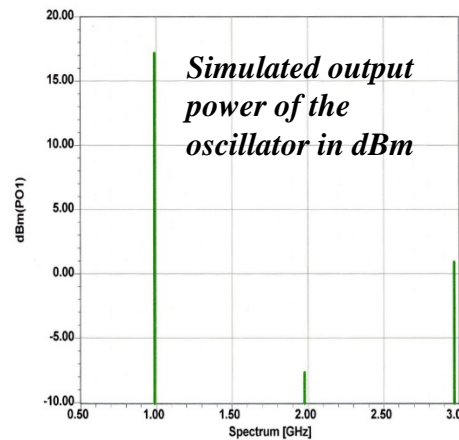

Simulated output power of the oscillator in dBm

2400 MHz MOSFET-Based Push-Pull Oscillator

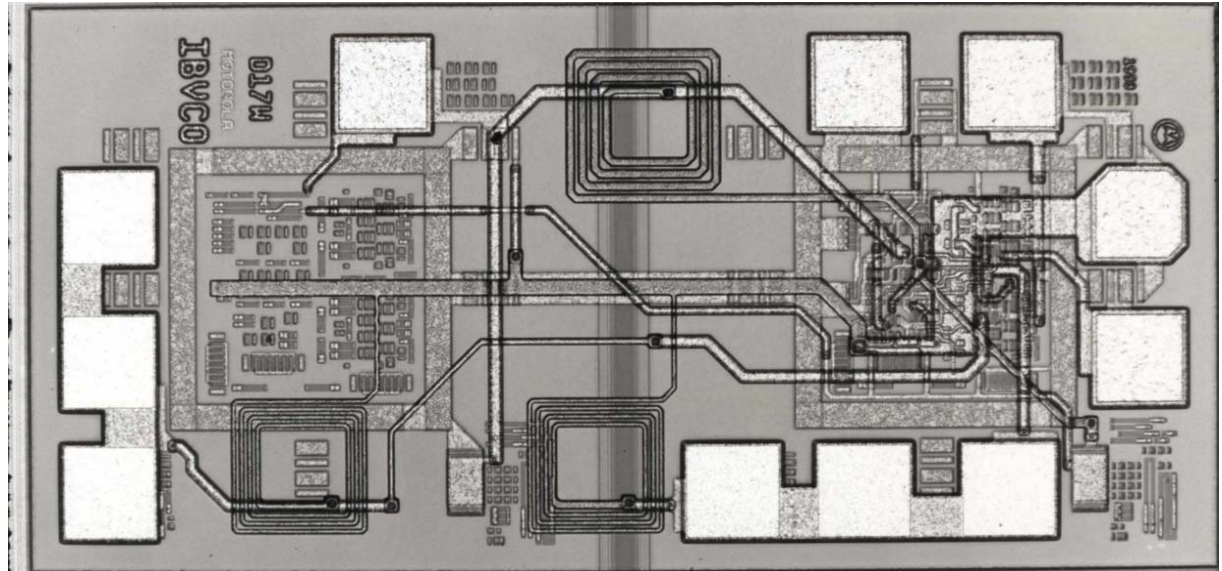
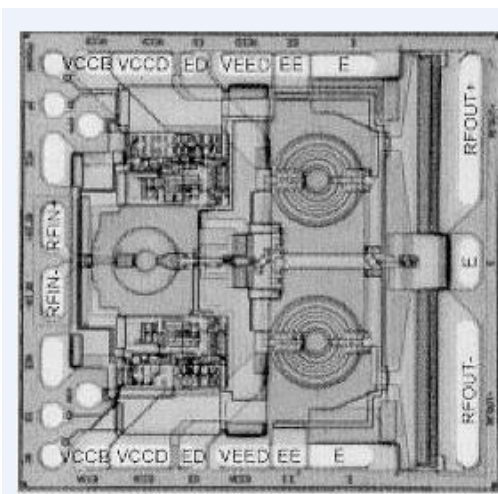

A Symmetric LC Oscillator

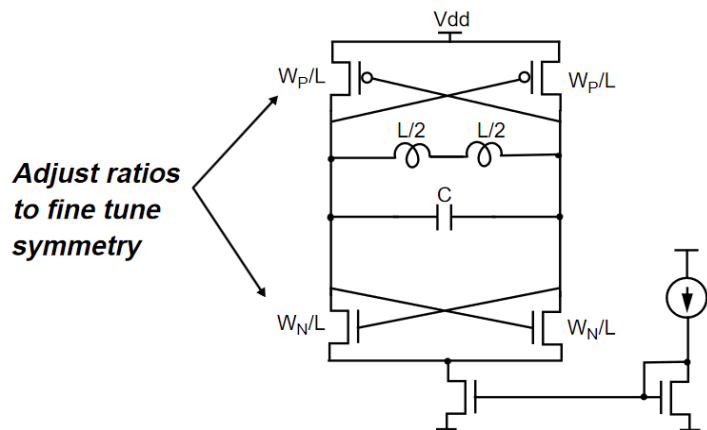

Uses the same current twice for high transconductance.

[Also appears in: J.Craninckx, et al, Proceedings of CICC 97.]

Most mixers in RFIC's are built on the principle of differential amplifiers (Gilbert cell) and require a phase and out of phase signal (symmetrical drive). For these symmetrical requirements, this is best achieved using a push-pull technology with two outputs. The design choices are SiGe transistors or BiCMOS transistors, and the critical phase noise is determined by the Q of the inductor and other elements of the resonator and by the flicker noise from the device.

OUTLINE

- **Introduction**
- **What is an oscillator?**
- **Introduction to Microwave Oscillators and Their Mathematical Treatment**
- **Transistor Types**
- **Transistor models and Noise Contributions**
- **Linear Approach to the Calculation of Oscillator Phase Noise**
- **Typical Microwave Oscillator (Colpitts Oscillator)**
- **Designing an Oscillator**
- **Tuning Diode Noise Contribution**
- **Designing an Oscillator based on Linear S-Parameters**
- **Large signal Operation of Oscillators (Colpitts/YIG)**
- **Classical Linear Two-Port Oscillator Design**
- **Microwave Resonators**
- **A Novel Tunable Active Spiral Inductor**
- **The Active Inductor Using a Gyrator**
- **INTRODUCTION: Active Inductor Oscillator**
- **Synthesized Inductor Circuits**
- **Phase Noise Contribution of the Various Parts of the Oscillator Using an Active Inductor**
- **The Modern Time-Domain Behavior of an Oscillator**
- **Test Case: Design Example of a 100MHz crystal oscillator**
- **Phase Noise Analysis Based on the Negative Resistance Model**
- **Oscillator Phase Noise**
- **Design Examples of Oscillators for Best Phase Noise and Good Output Power**
- **Phase Noise of the integrated CMOS oscillator**
- **A Solution for Calculating Phase Noise in Oscillators**
 - **Oscillator Noise Models**
 - **Noise Generation in Oscillators**
- **Key References**

➤ PHASE NOISE OF THE INTEGRATED CMOS OSCILLATOR

Symmetrical NMOS/PMOS Osc

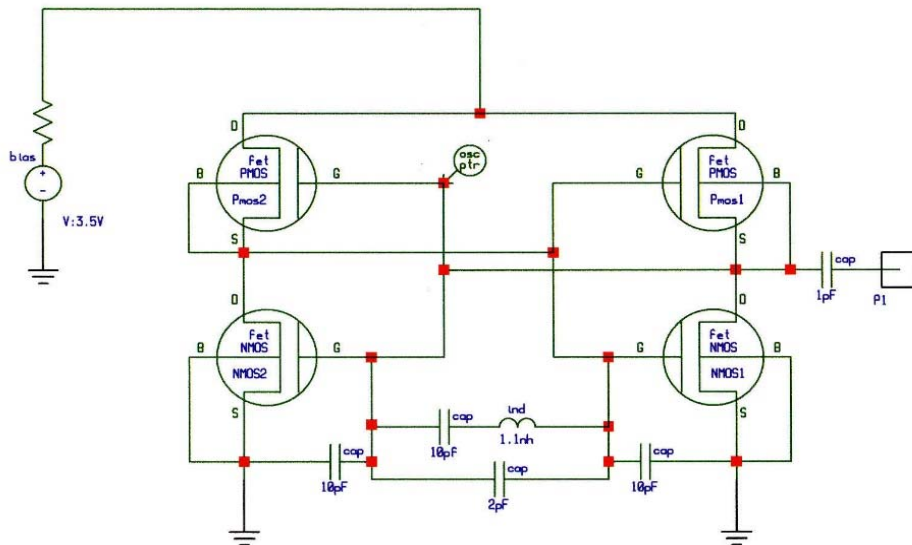

Circuit of the 2400 MHz integrated CMOS oscillator

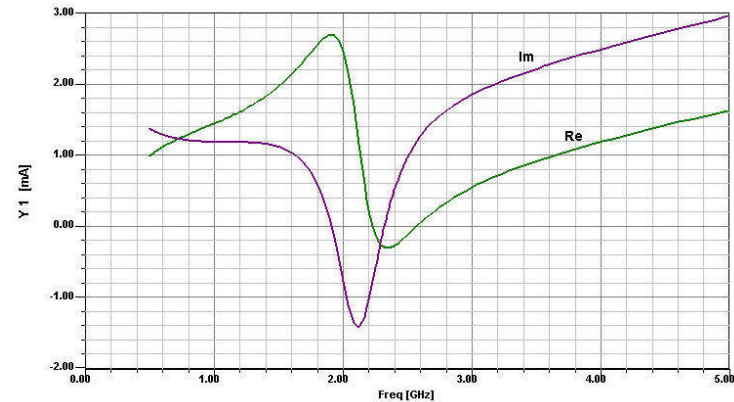
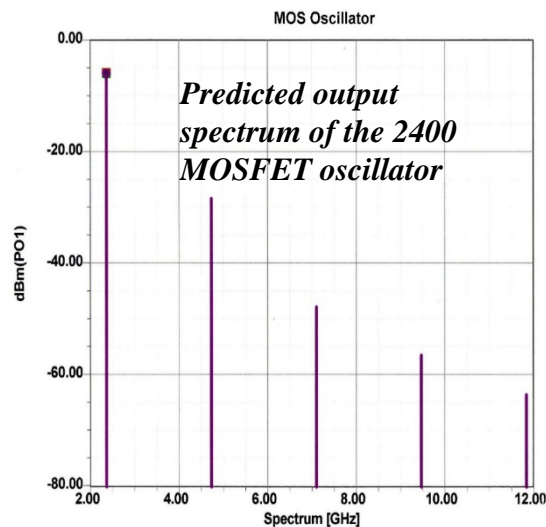
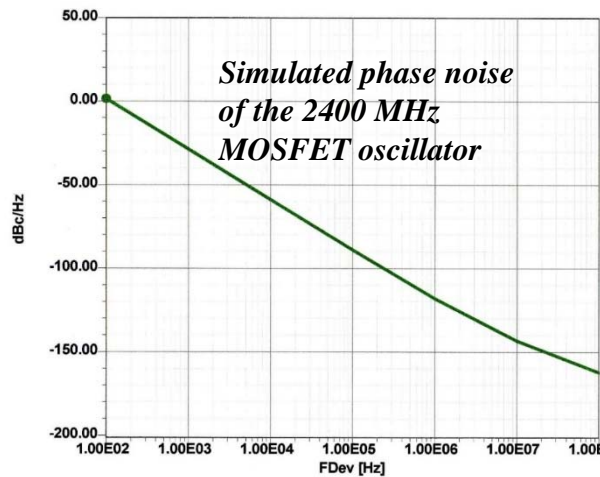

The real and imaginary currents which causes the negative resistance for oscillation

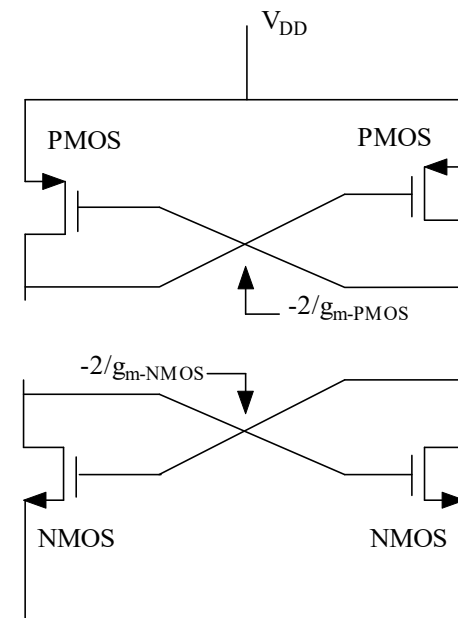

Determining the transconductance of the differential circuit of the cross-coupled PMOS and NMOS pair

➤ PHASE NOISE OF THE INTEGRATED CMOS OSCILLATOR

The phase noise of CMOS oscillators has been subject to endless discussions. The main contributors still are the resonant circuit with a low Q and the flicker frequency contribution from the device.

$$PN_{imf}(\omega_0 + \omega) = \frac{4KT}{R_p} [NFT_{brr}(\omega_0)]^2 = \frac{4KT}{R_p} \left\{ \frac{1}{2} \left[\frac{1}{2\omega_0 C_{eft}} \right] \left[\frac{\omega_0}{\omega} \right] \right\}^2$$

→ phase noise contribution from the resonator.

$$\begin{aligned} PN_{V_{gn}}(\omega_0 + \omega) &= 4KT_g [NFT_{V_{gm}}(\omega_0)]^2 \\ &= 4KTr_g \left\{ \frac{1}{2} \left[\frac{C_1 + C_2}{C_2} \left[\frac{1}{2Q_0} \right] \frac{\omega_0}{\omega} \right] \right\}^2 \end{aligned}$$

→ phase noise contribution from the gate resistance.

$$PN_{bgr}(\omega_0 + \omega) = 2qI_g [NFT_{kg}(\omega_0)]^2 = 2qI_R \left\{ \frac{1}{2} \left[\frac{C_2}{C_1 + C_2} \right] \left[\frac{1}{\omega_0 C_{cft}} \right] \left[\frac{\omega_0}{\omega} \right] \right\}^2$$

→ phase noise contribution from the gate current.

$$\begin{aligned} PN_{sm}(\omega_0 + \omega) &= \left(\frac{8kTgm}{3} + \frac{K_f I_z^{*F}}{f_m^F} \right) \left[NF_{yk}(\omega_0) \right]^2 = \left(\frac{8kTgm}{3} + \frac{K_f I_\epsilon^{NF}}{\omega} \right) \left\{ \frac{1}{2} \left[\frac{C_2}{C_1 + C_2} \left[\frac{1}{2\omega_0 Q_0 C_{es}} \right] \left[\frac{\omega_0}{\omega} \right] \right] \right\}^2 \end{aligned}$$

→ phase noise contribution from the flicker noise of the transistor.

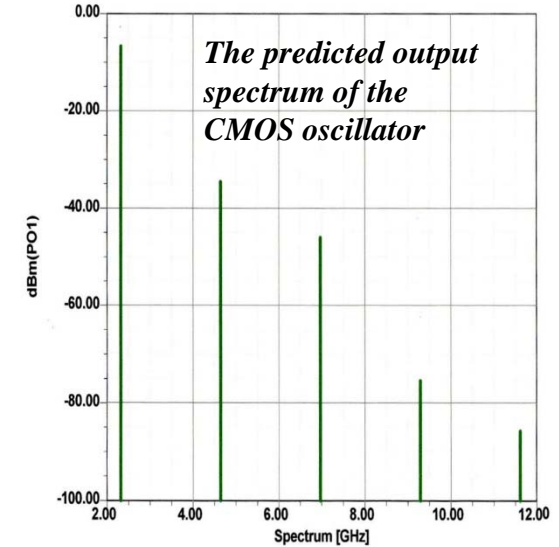

➤ PHASE NOISE OF THE INTEGRATED CMOS OSCILLATOR

The total effect of all the four noise sources can be expressed as

$$\begin{aligned}
 PN(\omega_0 + \omega) &= [PN_{inr}(\omega_0 + \omega)] + [PN_{Vgn}(\omega_0 + \omega)] + \\
 & [PN_{tgn}(\omega_0 + \omega)] + [PN_{tjn}(\omega_0 + \omega)] + [PN_{tdn}(\omega_0 + \omega)] \\
 \\
 PN(\omega_0 + \omega) &= \frac{4KT}{R_F} \left\{ \frac{1}{2} \left[\frac{1}{2\omega_0 C_{ef}} \left[\frac{\omega_0}{\omega} \right] \right]^2 + 4KT_g \left\{ \frac{1}{2} \left[\frac{C_1 + C_2}{C_2} \right] \left[\frac{1}{2Q} \right] \frac{\omega_0}{\omega} \right\} \right\}^2 \\
 & + \left[2qI_g + \frac{8kTgm}{3} + \frac{2\pi K_f I_g^{AF}}{\omega} \right] \left\{ \frac{1}{2} \left[\frac{C_2}{C_1 + C_2} \left[\frac{1}{2Q\omega_0 C_{eff}} \right] \left[\frac{\omega_0}{\omega} \right] \right\}^2 \right. \\
 & \left. + {}_{2qI_d} \left\{ \frac{1}{2} \left[\frac{C_3}{C_1 + C_2} \left[\frac{1}{2\omega_0 Q C_{v\sigma}} \right] \left[\frac{\omega_0}{\omega} \right] \right\}^2 \right.
 \end{aligned}$$

where

K_f = Flicker noise constant,

AF = Flicker noise exponent.

$$C_{eff} = C + \frac{C_1 C_2}{C_1 + C_2}$$

The following values were used for the calculation of the phase noise.

$$R_p = 190\Omega$$

$$f_0 = 2.4 \text{ GHz}$$

$$L = 1.1\text{nH}$$

$$C_O = 2\text{pF}$$

$$C_1 = C_2 = 0.2\text{pF}$$

$$n = 2$$

$$I_g = 100\mu\text{A}$$

$$I_d = 14\text{mA}$$

$$AF = 2$$

$$KF = 5\text{E-}5$$

$$q = 1.6\text{E-}19$$

$$T = 290^\circ \text{ K}$$

and the following contributions were obtained at 1 MHz offset

$$PN1 = -117.78 \text{ dBc/Hz}$$

$$PN2 = -146.37 \text{ dBc/Hz}$$

$$PN3 = -123.4 \text{ dBc/Hz}$$

$$PN4 = -140.9 \text{ dBc/Hz}$$

These calculations show that the phase noise contribution from the tuned circuit dominates and sets the value at -117.78 dBc/Hz .

The circuit was then analyzed using Microwave Harmonica/Ansoft Designer, using a lossy circuit with a Q_0 of 10 and using the SPICE-type parameters which were obtained from the manufacturer

OUTLINE

- **Introduction**
- **What is an oscillator?**
- **Introduction to Microwave Oscillators and Their Mathematical Treatment**
- **Transistor Types**
- **Transistor models and Noise Contributions**
- **Linear Approach to the Calculation of Oscillator Phase Noise**
- **Typical Microwave Oscillator (Colpitts Oscillator)**
- **Designing an Oscillator**
- **Tuning Diode Noise Contribution**
- **Designing an Oscillator based on Linear S-Parameters**
- **Large signal Operation of Oscillators (Colpitts/YIG)**
- **Classical Linear Two-Port Oscillator Design**
- **Microwave Resonators**
- **A Novel Tunable Active Spiral Inductor**
- **The Active Inductor Using a Gyrator**
- **INTRODUCTION: Active Inductor Oscillator**
- **Synthesized Inductor Circuits**
- **Phase Noise Contribution of the Various Parts of the Oscillator Using an Active Inductor**
- **The Modern Time-Domain Behavior of an Oscillator**
- **Test Case: Design Example of a 100MHz crystal oscillator**
- **Phase Noise Analysis Based on the Negative Resistance Model**
- **Oscillator Phase Noise**
- **Design Examples of Oscillators for Best Phase Noise and Good Output Power**
- **Phase Noise of the integrated CMOS oscillator**
- **A Solution for Calculating Phase Noise in Oscillators**
 - **Oscillator Noise Models**
 - **Noise Generation in Oscillators**
- **Key References**

➤ OSCILLATOR NOISE MODELS &

➤ NOISE GENERATION IN OSCILLATORS

Rohde's Modified Leeson's Phase-Noise Equation

$$L(f_m) = 10 \log \left\{ \left[1 + \frac{f_0^2}{(2f_m Q_L)^2 \left(1 - \frac{Q_L}{Q_0}\right)^2} \right] \left(1 + \frac{f_c}{f_m} \right) \frac{FkT}{2P_{sav}} + \frac{2kTRK_0^2}{f_m^2} \right\}$$

$L(f_m)$ = SSB noise power spectral density defined as ratio of sideband power in 1-Hz bandwidth at f_m to total power in dB, unit is dBc/Hz.

f_m = frequency offset

f_0 = center frequency

f_c = flicker frequency- region between $1/f^3$ - $1/f^2$

Q_L = loaded Q of the tuned circuit

Q_0 = unloaded Q of the tuned circuit

F = noise figure of the oscillator

$kT = 4.1 \times 10^{-21}$ at 300 K₀ (room temperature)

P_{sav} = average power at oscillator output

R = equivalent noise resistance of tuning diode

K_0 = oscillator voltage gain

Leeson has introduced a linear approach for calculation of oscillator phase noise and his noise formulae was extended by Rohde by adding the term $\frac{2kTRK_0^2}{f_m^2}$

responsible for the modulation noise

Shortcomings of the Modified Leeson Noise Equation

F is empirical, apriori, and difficult to calculate due to Linear Time Variant (LTV) characteristics of the noise.

Phase noise in $1/f^3$ region is an empirical expression with fitting parameters

Lee and Hajimiri Noise Model

This very nice model, unfortunately gives no insight in the contribution of the semiconductor used and only the flicker noise is discussed and the other noise sources for either the bipolar transistor or the variation of the FET are not considered

The Nonlinear Approach for the Computation of the Noise Analysis of Oscillator Circuits

Traditional approaches relying on frequency conversion analysis are not sufficient to describe the complex physical behavior of a noisy oscillator. The accuracy of this nonlinear approach is based on the dynamic range of the harmonic-balance simulator and the quality of the parameter extraction for the active device

➤ A SOLUTION FOR CALCULATING PHASE NOISE IN OSCILLATORS

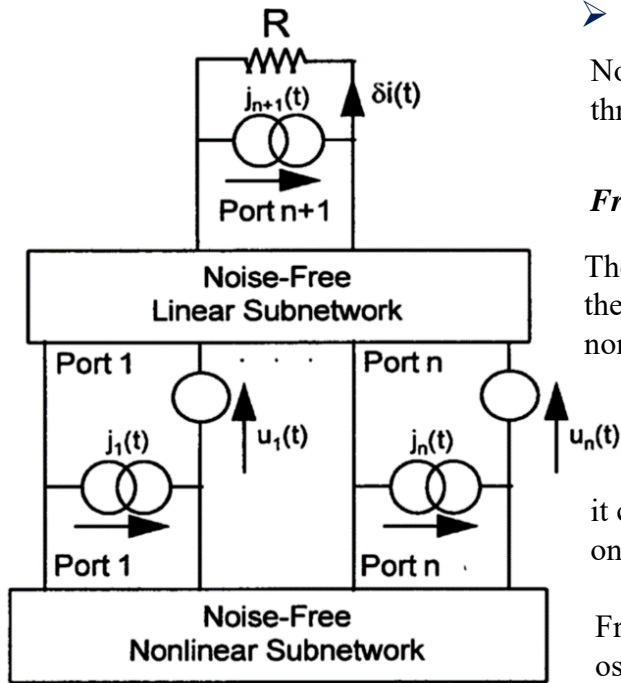

A general noisy nonlinear network

➤ Noise Generation in Oscillators

Noise components at high frequency deviations result in phase modulation of the carrier through mean-square phase fluctuation proportional to the available noise power

Frequency Conversion Approach

The noise performance of the circuit is determined by the exchange of the power between the sidebands of the unperturbed steady state through frequency conversion in the nonlinear subnetwork. From the expression

$$M_{BB} \partial X_B = J_B(\omega)$$

it can be seen that the oscillator noise is essentially an additive noise that is superimposed on each harmonic of a lower and upper sideband at the same frequency offset

Frequency conversion analysis correctly predicts the far-carrier noise behavior of an oscillator, but the oscillator noise floor does not provide results consistent with the physical observations at low frequency deviations from the carrier, which can be removed by adding the modulation noise analysis

Modulation Noise Analysis

PM noise due to noise modulation, AM noise due to noise modulation, and PM-AM correlation coefficient due to noise modulation can be expressed in terms of a simple algebraic combination of equations.

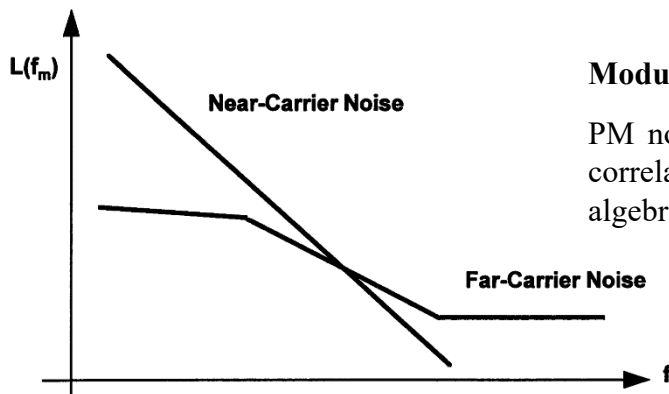

Oscillator noise components

➤ SOME KEY REFERENCES & FURTHER READINGS

1. M. Odyniec, Editor, *RF and Microwave Oscillator Design*, Chapter 5: Modern Harmonic-Balance Techniques for Oscillator Analysis and Optimization, by V. Rizzoli, A. Neri, A. Costanzo, F. Mastri, Artech House, 2002.
2. U.L. Rohde, C.R Chang, J. Gerber, "Design and Optimization of Low-Noise Oscillators Using Nonlinear CAD Tools," IEEE Frequency Control Symp. Proc., pp 548-554, 1994.
3. U. L. Rohde, C. R. Chang, J. Gerber, "Parameter Extraction for Large Signal Noise Models and Simulation of Noise in Large Signal Circuits Like Mixers and Oscillators," Proceedings of the 23rd European Microwave conference, Madrid, Spain, Sept. 6-9, 1993.
4. V. Rizzoli, F. Mastri, C. Cecchefti, "Computer-Aided Noise Analysis of MESFET and HEMT Mixers," IEEE Trans. Microwave Theory and Techniques, Vol. MTT-37, pp 1401-1410, Sept. 1989.
5. V. Rizzoli, A. Lippadni, "Computer-Aided Noise Analysis of Linear Multiport Networks of Arbitrary Topology," IEEE Trans. Microwave Theory and Techniques, Vol. MTT-33, pp 1507-1512, Dec. 1985.
6. V. Rizzoli, F. Mastri, D. Masotti, "General-Purpose Noise Analysis of Forced Nonlinear Microwave Circuits," Military Microwave, 1992.
7. W. Anzill, F. X. Kärtner, P. Russer, "Simulation of the Single-Sideband Phase Noise of Oscillators," Second International Workshop of Integrated Nonlinear Microwave and Millimeterwave Circuits, 1992.
8. U. L. Rohde, Matthias Rudolph RF/Microwave Circuit Design for Wireless Applications, Second Edition, Wiley, 2013
9. Anisha M. Apte, "A New Analytical Design Method of Ultra-low-noise Voltage Controlled VHF Crystal Oscillators and it's Validation", Ph.D. Dissertation Brandenburgischen Technischen Universität Cottbus–Senftenberg, February, 2020
10. Fundamentals of RF and Microwave Techniques and Technologies Kindle Edition by [Hans L. Hartnagel](#), [Rüdiger Quay](#), [Ulrich L. Rohde](#), [Matthias Rudolph](#), Springer 2023
11. Microwave Circuit Design Using Linear and Nonlinear Techniques 3rd Edition by [George D. Vendelin](#), [Anthony M. Pavio](#), [Ulrich L. Rohde](#), [Matthias Rudolph](#), Wiley 2021
12. Microwave and Wireless Synthesizers: Theory and Design, 2nd Edition by [Ulrich L. Rohde](#), [Enrico Rubiola](#), [Jerry C. Whitaker](#) Wiley, 2021
13. Wolfgang Griebel, "[Space Qualified 5MHz Crystal Oscillators with Maximum Stability between 1 and 10 Seconds](#)", Ph. D. dissertation Brandenburgischen Technischen Universität Cottbus–Senftenberg, April, 2021

REFERENCES: FURTHER READINGS

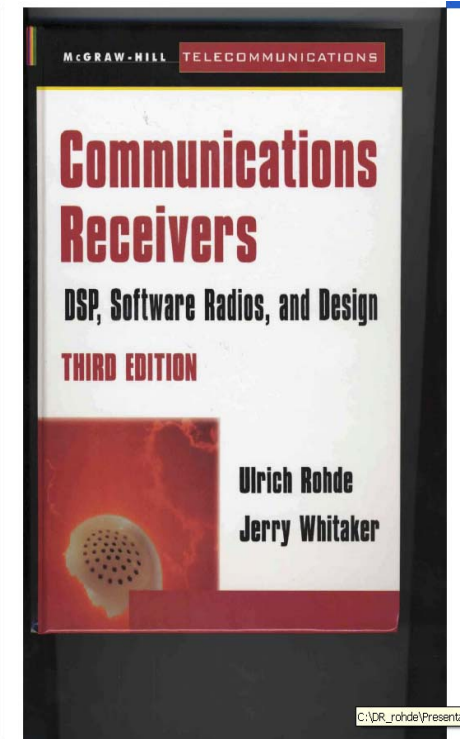
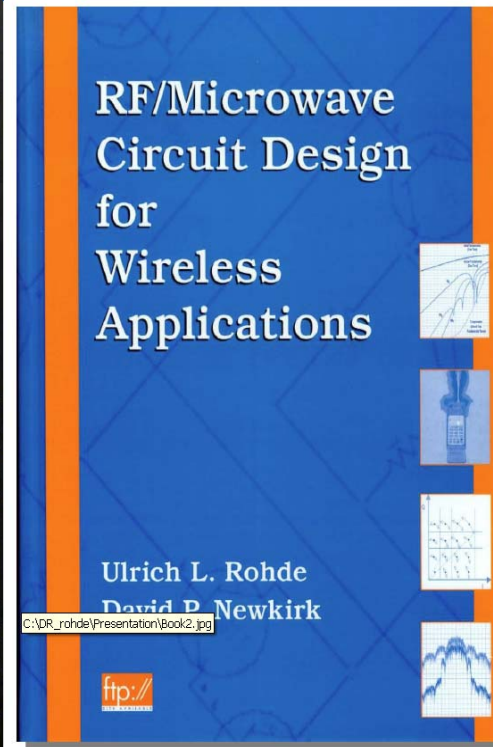
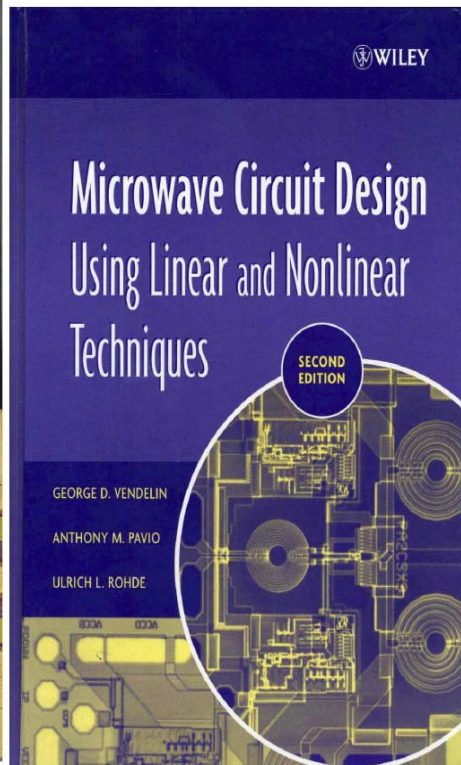
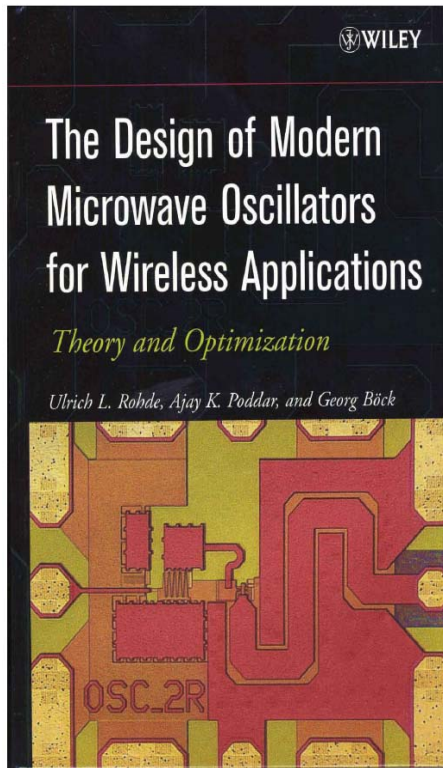

Thank You For Your Attention !

